



Austrian Institute of Construction Engineering  
 Schenkenstrasse 4 | T+43 1 533 65 50  
 1010 Vienna | Austria | F+43 1 533 64 23  
 www.oib.or.at | mail@oib.or.at



## European Technical Assessment

**ETA-16/0523**  
 of 23.05.2017

General part

**Technical Assessment Body issuing the European Technical Assessment**

Österreichisches Institut für Bautechnik (OIB)  
 Austrian Institute of Construction Engineering

**Trade name of the construction product**

PROMASTOP®-CC

**Product family to which the construction product belongs**

Fire Stopping and Fire Sealing Products:  
 Penetration Seals

**Manufacturer**

Promat International NV  
 Bormstraat 24  
 2830 Tiselt  
 BELGIUM

**Manufacturing plant**

Production plant 16

**This European Technical Assessment contains**

93 pages including Annexes 1 to 5 which form an integral part of this assessment

**This European Technical Assessment is issued in accordance with Regulation (EU) No 305/2011, on the basis of**

Guideline for European technical approval for "Fire Stopping and Fire Sealing Products", ETAG 026 Part 2: "Penetration Seals", edition August 2011, used as European Assessment Document (EAD)

This European Technical Assessment is not to be transferred to manufacturers or agents of manufacturer other than those indicated on page 1, or manufacturing plants other than those laid down in the context of this European Technical Assessment.

Translations of this European Technical Assessment in other languages shall fully correspond to the original issued document and should be identified as such.

Communication of this European Technical Assessment, including transmission by electronic means, shall be in full. However, partial reproduction can be made with the written consent of the Österreichisches Institut für Bautechnik. In this case, partial reproduction has to be designated as such.

This European Technical Assessment may be withdrawn by the Österreichisches Institut für Bautechnik, in particular pursuant to information by the Commission according to Article 25 (3) of Regulation (EU) No 305/2011.

electronic copy  
electronic copy  
electronic copy  
electronic copy  
electronic copy  
electronic copy  
electronic copy

Specific parts

## 1 Technical description of the product

PROMASTOP®-CC is a water based endothermic intumescent firestop coating used in combination with mineral wool boards. PROMASTOP®-CC is intended to be used to form a cable- and/or pipe penetration seal (mixed penetration seal). The firestop coating is ready for use and can be diluted by adding max. 5 % water, if needed. The application can be done by spray (airless), rolls or brush. All visible surfaces of the mineral wool boards shall be coated single sided.

The firestop coating PROMASTOP®-CC is available in one viscosity:

- > PROMASTOP®-CC (paint / liquid)

Pre-coated mineral wool boards with PROMASTOP®-CC are available under different trade names as specified in the following table.

Trade name	Thickness of mineral wool boards	Coating
PROMASTOP®-CC CB5 2s	50 mm	two-sided
PROMASTOP®-CC CB5 1s	50 mm	one-sided
PROMASTOP®-CC CB8 2s	80 mm	two-sided

For specification of suitable mineral wool boards see Annex 2 of the ETA.

A detailed specification of the product PROMASTOP®-CC is a non-public part of this European technical assessment, and deposited at the Österreichisches Institut für Bautechnik.

## 2 Specification of the intended use(s) in accordance with the applicable European Assessment Document

### 2.1 Intended use

The firestop coating PROMASTOP®-CC is intended to be used to form a cable- and/or pipe penetration seal (mixed penetration seal) to temporarily or permanently reinstate the fire resistance performance of flexible wall constructions, rigid wall constructions and rigid floor constructions where they have been provided with apertures which are penetrated by various cables, conduits / tubes, metal pipes, plastic pipes, multi-layer composite pipes, aluminium-composite pipes and cable support constructions (perforated or non-perforated steel cable trays and steel ladders).

The firestop coating PROMASTOP®-CC shall be used in conjunction with the following additional components (for details see Annex 3 of the ETA):

- > Firestop collar PROMASTOP®-FC
- > Firestop acrylate PROMASEAL®-A
- > Firestop wrap PROMASTOP®-W

The maximum seal sizes of the penetration seal in the different separating elements are given in Annex 3 of the ETA.

Blank penetration seals with maximum opening sizes as specified in Annex 3 of the ETA have been tested.

The cable- and/or pipe penetration seal made firestop coating PROMASTOP®-CC and additional components can be installed only in the types of separating elements as specified in the following table (for details see Annex 3 of the ETA).

Separating element	Construction
Flexible walls	<ul style="list-style-type: none"> <li>&gt; Steel studs or timber studs lined on both faces with minimum 2 layer of boards (minimum thickness 12,5 mm) with classification A2-s1,d0 or A1 according to EN 13501-1</li> <li>&gt; For timber stud walls there shall be a minimum distance of 100 mm of the penetration seal to any timber stud. The cavity between the penetration seal and the timber stud has to be closed with minimum 100 mm of insulation with classification A1 or A2 according to EN 13501-1</li> <li>&gt; Minimum thickness 100 mm</li> <li>&gt; Classification according to EN 13501-2: ≥ EI 60 (only for 1 x 50 mm PROMASTOP®-CC penetration seal)</li> <li>&gt; Classification according to EN 13501-2: ≥ EI 90 (only for 1 x 80 mm and 2 x 50 mm PROMASTOP®-CC penetration seal)</li> <li>&gt; The aperture lining shall be made from steel studs with a thickness of minimum 0,6 mm and / or boards of the same specification as those used in the wall in practice</li> <li>&gt; This European Technical Assessment does not cover sandwich panel constructions and flexible walls were the lining does not cover studs on both sides. Penetrations in such constructions shall be tested on a case by case basis.</li> </ul>
Rigid walls	<ul style="list-style-type: none"> <li>&gt; Aerated concrete, concrete, masonry</li> <li>&gt; Minimum density 450 kg/m<sup>3</sup> Minimum thickness 100 mm</li> <li>&gt; The rigid wall shall be classified in accordance with EN 13501-2 for the required fire resistance period</li> </ul>
Rigid floors	<ul style="list-style-type: none"> <li>&gt; Aerated concrete, concrete</li> <li>&gt; Minimum density 450 kg/m<sup>3</sup> Minimum thickness 150 mm</li> <li>&gt; The rigid floor shall be classified in accordance with EN 13501-2 for the required fire resistance period</li> </ul>

PROMASTOP®-CC may be used as a penetration seal with the following specific installations (For further details see Annex 3 of the ETA):

- > Plastic pipes made of PVC-U, PE-HD, PP-H, PP-R
- > Aluminium-composite pipe, type Pipelife Radopress, Geberit Mepla, Viega Raxofix, Viega Sanfix Fosta
- > Metal pipes (with insulations) made of steel, copper, cast iron, Ni-alloys Viega Sanpress, Viega Sanpress XL, Viega Sanpress Inox, Viega Sanpress Inox XL, Viega Sanpress Inox G, Viega Sanpress Inox G XL
- > Multilayer-composite pipes from manufacturer Rehau, Poloplast, Geberit, Friatec or Pipelife
- > Cables and cable bundles (sheathed and non-sheathed)
- > Small conduits and tubes (Ø ≤ 16 mm) made of plastic or steel
- > Cable support constructions (perforated or non-perforated steel cable trays and steel ladders)

electronic copy

Other parts or service support constructions shall not penetrate the penetration seal.

## 2.2 Use category

PROMASTOP®-CC is intended for use in conditions exposed to weathering, and can therefore – according to ETAG 026-Part 2 clause 2.4.12.1.3.3 – be categorized as Type X.

Although a penetration seal is intended for indoor applications only, the construction process may result in it being subjected to more exposed conditions for a period before the building envelope is closed. For this case provisions shall be made to protect temporarily exposed penetration seals according to the ETA-holder's installation instructions.

## 2.3 Working life

The provisions made in this European Technical Assessment are based on an assumed working life of PROMASTOP®-CC of 10 years, provided the conditions laid down in the technical literature of the manufacturer relating to packaging, transport, storage, installation, use and repair are met.

The indications given on the intended working life cannot be interpreted as a guarantee given by the producer or the Technical Assessment Body, but are to be regarded only as a means for selecting the appropriate product in relation to the expected economically reasonable working life of the works.

The real working life might be, in normal use conditions, considerably longer without major degradation affecting the Basic requirements for construction works.

## 2.4 General assumptions

### 2.4.1 It is assumed that

- > damages to the penetration seal are repaired accordingly,
- > the installation of the penetration seal does not effect the stability of the adjacent building element – even in case of fire,
- > the lintel or floor above the penetration seal is designed structurally and in terms of fire protection such that no additional mechanical load (other than its own weight) is imposed on the penetration seal,
- > the aperture lining within a flexible wall is supported by the studs (transoms and mullions) in such a way that the mechanical load imposed to the aperture lining by the penetration seal does not affect the stability of the aperture lining and the flexible wall,
- > the thermal movement in the pipe work will be accommodated in such way that it does not impose a load on the penetration seal,
- > the installations are fixed to the adjacent building element in accordance with the relevant regulations in such a way that, in case of fire, no additional mechanical load is imposed to the penetration seal,
- > the support of the installations is maintained for the required period of fire resistance and
- > pneumatic dispatch systems, compressed air systems, etc. are switched off by additional means in case of fire.

2.4.2 This European Technical Assessment does not address any risks associated with the emission of dangerous liquids or gases caused by failure of the pipe(s) in case of fire nor does it prove the prevention of the transmission of fire through heat transfer via the medium in the pipes.

2.4.3 This European Technical Assessment does not verify the prevention of destruction of adjacent building elements with fire separating function or of the pipes themselves due to distortion forces caused by extreme temperatures. These risks shall be accounted for by taking appropriate measures when designing or installing the pipe work.

The mounting or hanging of the pipes or the layout of the pipe work shall be implemented in such a way that the pipes and the fire resistant building elements shall remain functional within a period of time which corresponds to the fire resistance period required.

2.4.4 The risk of downward spread of fire caused by burning material which drips through a pipe to floors below, is not considered in this European Technical Assessment (see EN 1366-3:2009, clause 1).

2.4.5 The durability assessment does not take account of the possible effect on the penetration seal of substances permeating through the pipe walls.

2.4.6 The assessment does not cover the avoidance of destruction of the penetration seal or of the adjacent building element(s) by forces caused by temperature changes in case of fire. This has to be considered when designing the piping system.

## 2.5 **Manufacturing**

The European Technical Assessment is issued for the product on the basis of agreed data/information, deposited with the Österreichisches Institut für Bautechnik, which identifies the product that has been assessed and judged. Changes to the product or production process, which could result in this deposited data/information being incorrect, should be notified to the Österreichisches Institut für Bautechnik before the changes are introduced.

The Österreichisches Institut für Bautechnik will decide whether or not such changes affect the European Technical Assessment and consequently the validity of the CE marking on the basis of the European Technical Assessment and if so whether further assessment or alterations to the European Technical Assessment, shall be necessary.

### 3 Performance of the product and references to the methods used for its assessment

Basic requirements for construction works	Essential characteristic	Method of verification	Performance
<b>BWR 2</b>	Reaction to fire	EN 13501-1	Clause 3.1.1 of the ETA
	Resistance to fire	EN 13501-2: 2007+A1:2009	Clause 3.1.2 of the ETA and Annex 3 of the ETA
<b>BWR 3</b>	Air permeability (material property)	No performance assessed	
	Water permeability (material property)	No performance assessed	
	Content and/or release of dangerous substances	European Council Directive 67/548/EEC and Regulation (EC) No 1272/2008 as well as EOTA TR 034, edition October 2015	Declaration of conformity by the manufacturer
<b>BWR 4</b>	Mechanical resistance and stability	No performance assessed	
	Resistance to impact / movement	No performance assessed	
	Adhesion	No performance assessed	
<b>BWR 5</b>	Airborne sound insulation	No performance assessed	
<b>BWR 6</b>	Thermal properties	No performance assessed	
	Water vapour permeability	No performance assessed	

#### 3.1 Safety in case of fire (BWR 2)

##### 3.1.1 Reaction to fire

The construction product PROMASTOP®-CC was assessed according to ETAG 026-Part 2 clause 2.4.1 and classified according to EN 13501-1:2007+A1:2009.

Component	Class according to EN 13501-1
PROMASTOP®-CC	<b>B-s1,d0</b>

##### 3.1.2 Resistance to fire

PROMASTOP®-CC was tested according to ETAG 026-Part 2 clause 2.4.2 and EN 1366-3:2009, in conjunction with EN 1363-1:1999 and EN 1363-1:2012.

Based upon the gained test results and the field of application specified within EN 1366-3:2009 the cable- and/or pipe penetration seal (mixed penetration seal) PROMASTOP®-CC has been classified according to EN 13501-2:2007+A1:2009. The individual fire resistance classes are listed in Annex 3 of the ETA.

The maximum fire resistance class of the penetration seal in vertical or horizontal separating element depends on the fire resistance class of the penetrating elements. The fire resistance class of the penetration seal is reduced to the fire resistance class of the penetrating element with the lowest fire resistance classification.

The resistance to fire classification listed in Annex 3 of the ETA is only valid if PROMASTOP®-CC is installed according to Annex 3 and Annex 4 of the ETA.

Information on ancillary products, which were tested within the framework of this European Technical Assessment for evaluating resistance to fire, is given in Annex 2 of the ETA.

### **3.2 Hygiene, health and environment (BWR 3)**

#### 3.2.1 Air permeability

No performance assessed.

#### 3.2.2 Water permeability

No performance assessed.

#### 3.2.3 Release of dangerous substances

According to the manufacturer's declaration the components of PROMASTOP®-CC do not contain dangerous substances detailed in Council Directive 67/548/EEC and Regulation (EC) no 1272/2008 as well as EOTA TR 034 (General BWR 3 Checklist for EADs/ETAs – Dangerous substances), edition October 2015.

A written declaration in this respect was submitted by the ETA-holder.

In addition to the specific clauses relating to dangerous substances contained in this European Technical Assessment, there may be other requirements applicable to the products falling within its scope (e.g. transposed European legislation and national laws, regulations and administrative provisions). In order to meet the provisions of the Construction Product Directive, these requirements need also to be complied with, when and where they apply.

### **3.3 Safety in use (BWR 4)**

#### 3.3.1 Mechanical resistance and stability

No performance assessed.

#### 3.3.2 Resistance to impact / movement

No performance assessed.

Provisions shall be taken to prevent a person from stepping onto a horizontal penetration seal or falling against a vertical penetration seal (e.g. by covering with a wire mesh).

#### 3.3.3 Adhesion

No performance assessed.

### **3.4 Protection against noise (BWR 5)**

#### 3.4.1 Airborne sound insulation

No performance assessed.



### 3.5 Energy economy and heat retention (BWR 6)

#### 3.5.1 Thermal properties

No performance assessed.

#### 3.5.2 Water vapour permeability

No performance assessed.

### 3.6 General aspects relating to fitness for use

PROMASTOP®-CC fulfils the requirements for the intended use category.

PROMASTOP®-CC is therefore appropriate for use in conditions exposed to weathering, and can therefore – according to ETAG 026-Part 2 clause 2.4.12.1.3.3 – be categorized as Type X.

## 4 Assessment and verification of constancy of performance (hereinafter AVCP) system applied, with reference to its legal base

### 4.1 AVCP system

According to the Decision 1999/454/EC<sup>1</sup>, amended by Decision 2001/596/EC<sup>2</sup> of the European Commission the system(s) of assessment and verification of constancy of performance (see Annex V of Regulation (EU) No 305/2011) is given in the following table.

Product(s)	Intended use(s)	Level(s) or class(es) (resistance to fire)	System of assessment and verification of constancy of performance
Fire Stopping and Fire Sealing Products	for fire compartmentation and/or fire protection or fire performance	any	1

In addition, according to the Decision 1999/454/EC, amended by Decision 2001/596/EC of the European Commission the system(s) of assessment and verification of constancy of performance, with regard to reaction to fire, is given in the following table.

Product(s)	Intended use(s)	Level(s) or class(es) (reaction to fire)	System of assessment and verification of constancy of performance
Fire Stopping and Fire Sealing Products	for uses subject to regulations on reaction to fire	A1*, A2*, B*, C*	1
		A1**, A2**, B**, C**, D, E	3
		(A1 to E)***, F	4
<p>* Products/materials for which a clearly identifiable stage in the production process results in an improvement of the reaction to fire classification (e.g. an addition of fire retardants or a limiting of organic material)</p> <p>** Products/materials not covered by footnote (*)</p> <p>*** Products/materials that do not require to be tested for reaction to fire (e.g. products/materials of class A1 according to Commission Decision 96/603/EC, as amended)</p>			

<sup>1</sup> Official Journal of the European Communities no. L 178, 14.7.1999, p. 52

<sup>2</sup> Official Journal of the European Communities no. L 209, 2.8.2001, p. 33

**5 Technical details necessary for the implementation of the AVCP system, as provided for in the applicable European Assessment Document**

Technical details necessary for the implementation of the AVCP system are laid down in the control plan deposited with the Technical Assessment Body Österreichisches Institut für Bautechnik.

The notified product certification body shall visit the factory at least once a year for surveillance of the manufacturer.

Issued in Vienna on 23.05.2017  
by Österreichisches Institut für Bautechnik

The original document is signed by:

Rainer Mikulits  
Managing Director

electronic copy  
electronic copy  
electronic copy  
electronic copy  
electronic copy  
electronic copy  
electronic copy

## ANNEX 1

### Reference documents and list of abbreviations

#### 1.1 Reference to standards mentioned in this ETA

ETAG 026-2 (2011)	Fire stopping and fire sealing products - Part 2: Penetration Seals
EN 13501-1	Fire classification of construction products and building elements - Part 1: Classification using test data from reaction to fire tests
EN 13501-2:2007+A1:2009	Fire classification of construction products and building elements - Part 2: Classification using data from fire resistance tests, excluding ventilation
EN 1363-1:1999	Fire resistance tests - Part 1: General requirements
EN 1363-1:2012	Fire resistance tests - Part 1: General requirements
EN 1366-3:2009	Fire resistance tests for service installations - Part 3: Penetration seals

#### 1.2 Other reference documents

EOTA TR 024 (2009)	Characterisation, Aspects of Durability and Factory Production Control for Reactive Materials, Components and Products
--------------------	--

## ANNEX 2

### DESCRIPTION OF PRODUCT(S) & PRODUCT LITERATURE

#### 2.1 Product

Product name	Description
PROMASTOP®-CC	firestop coating
PROMASTOP®-FC (additional component)	firestop collar
PROMASTOP®-W (additional component)	firestop wrap
PROMASEAL®-A (additional component)	firestop acrylic sealant
PROMASEAL®-AG (additional component)	intumescent firestop sealant

#### Suitable mineral wool products used for mineral wool board penetration seal and for pre-coated mineral wool boards

Manufacturer	Product designation
Rockwool	RP-XV, Hardrock 040 / Hardrock II, Rockwool 360, Taurox D-C, Taurox Duo NP, Rockwool Paneel 755
Knauf Insulations	Knauf Insulations DP-15, Knauf Insulations FDB D150
Paroc OY AB	Pyrotech slab 140 – 180, Paroc Pro Roof Slab
Isover	Orsil T-N

#### Suitable insulation products – reaction to fire

Combustible insulation (closed cell, flexible elastomeric foam, e.g. AF/Armaflex)	minimum B-s3,d0 (acc. to EN 13501-1)
Combustible insulation for sound decoupling (elastomeric foam made from PE, e.g. Kaiflex PE-AB Abflusisolierung)	minimum E (acc. to EN 13501-1)
Non-combustible insulation (stone wool) (e.g. Rockwool 800, Rockwool Klimarock, Conlit 150U, Heralan Lam-040-AR)	minimum A2-s1,d0 / A2 <sub>L</sub> -s1,d0, A2 <sub>L</sub> (acc. to EN 13501-1)

For backfilling (annular gaps) if necessary, mineral wool with a melting point  $\geq 1000$  °C and classification A1 according to EN 13501-1 shall be used.

#### 2.2 Fixing details

Threaded steel rods M6 or M8 with nuts and washers for fixing the firestop collars on penetration seals made of mineral wool boards. For the built in situation of the firestop collar, fastening hooks in between the mineral wool boards shall be used. The built in situation can be only used for the double board penetration seal.

The insulation shall be placed in the center of the PROMASTOP®-CC penetration seal and fixed with steel wire (minimum thickness 0,6 mm).

#### 2.3 Transport and storage

The indications of the manufacturer regarding transport and storage (minimum and maximum storing temperature, maximum duration of storage) have to be followed.

## **2.4 Use, maintenance and repair**

The fire resistance of the penetration seal shall not be negatively affected by future changes to buildings or building elements.

The assessment of the fitness for use is based on the assumption that necessary maintenance and repair if required is carried out in accordance with the manufacturer's instructions during the assumed intended working life.

## **2.5 Technical product literature**

Product data sheets for PROMASTOP®-CC, PROMASTOP®-FC, PROMASTOP®-W, PROMASEAL®-A and PROMASEAL®-AG

Detailed sketches for the firestop coating PROMASTOP®-CC in conjunction with PROMASTOP®-FC, PROMASTOP®-W, PROMASEAL®-A and PROMASEAL®-AG

### ANNEX 3

#### RESISTANCE TO FIRE CLASSIFICATION OF PROMASTOP®-CC

##### 3.1 Classification acc. to EN 13501-2 for the PROMASTOP®-CC firestop coating with mineral wool boards

Thickness of the mineral wool board penetration seals with PROMASTOP®-CC firestop coating:

Mineral wool boards (number of layers x thickness)	1 x 50 mm
Mineral wool boards (number of layers x thickness)	1 x 80 mm
Mineral wool boards (number of layers x thickness)	2 x 50 mm

Maximum seal size depending on the separating element (see clause 2.1 of the ETA):

Supporting construction	Penetration seal version		
	1 x 50 mm	1 x 80 mm	2 x 50 mm
Flexible walls	1000 mm x 3000 mm (width x height)	1000 mm x 3000 mm (width x height)	1000 mm x 3000 mm (width x height)
Rigid walls	1000 mm x 3000 mm (width x height)	1000 mm x 3000 mm (width x height)	1000 mm x 3000 mm (width x height)
Rigid floors	see Annex 5 of the ETA		

Mineral wool boards thickness see table above, minimum density 140 kg/m<sup>3</sup>, melting point ≥ 1000°C and class A1 acc. to EN 13501-1 (possible products see Annex 2, clause 2.1 of the ETA).

Classification of the PROMASTOP®-CC blank seals depending on the separating element (see clause 2.1 of the ETA):

Supporting construction	Classification		
	1 x 50 mm	1 x 80 mm	2 x 50 mm
Flexible walls	EI 60 / E 90	EI 120 / E 120	EI 120 / E 120
Rigid walls	EI 60 / E 90	EI 120 / E 120	EI 120 / E 120
Rigid floors	EI 60 / E 60	EI 120 / E 120	EI 120 / E 120

Distances between the mineral wool boards (only for 2 x 50 mm penetration seal):

Supporting construction	Distance (mm)
Flexible walls	0
Rigid walls	0 – 110
Rigid floors	0 – 170

Thickness of PROMASTOP®-CC firestop coating (dry layer thickness):

Specimen	Minimum thickness (mm)
On the surface of the penetration seal	0,7
On cable trays, cable ladders (plate and flanges)	1,0
All sheathed and non-sheathed cables and tied cable bundles	1,0
Small conduits and tubes (Ø ≤ 16 mm) made of plastic or steel	3,0

*Length of PROMASTOP®-CC firestop coating (measured from the surface of the penetration seal):*

Specimen	Minimum length (mm)
On the surface of the adjacent separating element (wall, floor)	0
On cable trays, cable ladders (plate and flanges)	100
All sheathed and non-sheathed cables and tied cable bundles	100
Small conduits and tubes ( $\varnothing \leq 16$ mm) made of plastic or steel	100

*Installations supports may penetrate the penetration seal:*

Specimen
Steel cable trays (perforated or non-perforated)
Steel ladders
Steel cable trays (perforated or non-perforated) and steel ladders with organic coatings shall at least be classified A2-s1,d0 according to EN 13501-1

Lidded cable trays / trunkings must not pass through the penetration seal.

In flexible wall constructions an aperture framing made from boards may be omitted in case the aperture is lined with metal studs.

PROMASTOP®-CC firestop coating shall be applied on the visible surface of the penetration seal, cutting edges and the reveal.

*Installations may penetrate the penetration seal (details are given in the specific parts in Annex 3 of the ETA):*

Specimen
Plastic pipes made of PVC-U, PE, PP-H, PP-R
Aluminium-composite pipe, type Pipelife Radopress, Geberit Mepla, Viega Raxofix, Viega Sanfix
Metal pipes (with insulations) made of steel, copper, cast iron, Ni-alloys
Multilayer-composite pipes from manufacturer Rehau, Poloplast, Geberit, Friatec, Pipelife
Cables and cable bundles (sheathed and non-sheathed)
Small conduits and tubes ( $\varnothing \leq 16$ mm) made of plastic or steel

The total cross sections of the installations (including insulations and cable support constructions) must not be more than 60 % of the opening size of the penetration seal.

The gap between the installations and the mineral wool boards has to be completely filled with mineral wool (stone wool with a melting point  $\geq 1000^{\circ}\text{C}$ , class A1 acc. to EN 13501-1 and a minimum apparent density of  $40 \text{ kg/m}^3$ ) and afterwards coated with PROMASTOP®-CC firestop coating or PROMASEAL®-A firestop acrylic sealant on both sides of the penetration seal. In rigid floors PROMASTOP®-CC firestop coating or PROMASEAL®-A firestop acrylic sealant only needs to be applied on the bottom side of the floor.

Supporting distances (measured from the surface of the penetration seal):

Orientation	Maximum distance (mm)
Distance on both sides of wall constructions	250
Distance on the top side of floor constructions	250

Pipe end configurations:

<i>Tested and classified for plastic pipes</i>	Applicable
U/U	U/U, C/U, U/C, C/C
U/C	U/C, C/C
<i>Tested and classified for metal pipes</i>	Applicable
U/C	C/U, U/C, C/C
<i>Tested and classified for aluminium-composite pipes</i>	Applicable
U/C	U/C, C/C

Conduits made of plastic were tested U/C.

Conduits made of steel were tested U/C.

Small conduits and tubes ( $\varnothing \leq 16$  mm) made of plastic or steel shall be sealed with PROMASEAL®-AG acrylic sealant or PROMASEAL®-A acrylic sealant and if need be mineral wool (stone wool with a melting point  $\geq 1000^\circ\text{C}$ , class A1 acc. to EN 13501-1 and a minimum apparent density of  $40 \text{ kg/m}^3$ ) as backfilling material.

*Sound decoupling:*

Sound decoupling (e.g. Kaiflex PE-AB Abflusisolierung from manufacturer Kaiman) based on PE (closed-cell elastomeric foam, maximum thickness 5 mm, class E acc. to EN 13501-1, maximum one layer) may be used (only to be used for plastic pipes).

*Couplings:*

The diameter of the tested pipe couplings can be reduced, but not increased. For this application PROMASTOP®-FC6 collar shall be used.

Conduits / tubes, metal pipes, plastic pipes, multi-layer composite pipes and aluminium-composite pipes shall be installed perpendicular to the surface of the penetration seal.



### 3.2 Classification acc. to EN 13501-2 for the PROMASTOP®-CC firestop coating on cables, cable bundles, small conduits and tubes ( $\varnothing \leq 16$ mm)

*All sheathed cable:*

All sheathed cable types currently and commonly used in building practice in Europe (e.g. control, power, data, optical fibre cables, signal, telecommunication).

*All non-sheathed cable:*

All non-sheathed cables (wires) currently and commonly used in building practice in Europe.

*Tied cable bundle:*

Tied cable bundle (maximum diameter 100 mm), maximum diameter of single cable 21 mm.

The gap (max. width 10 mm) between the installations and the mineral wool boards has to be completely filled with mineral wool (stone wool with a melting point  $\geq 1000^{\circ}\text{C}$ , class A1 acc. to EN 13501-1 and a minimum apparent density of  $40 \text{ kg/m}^3$ ) and afterwards coated with PROMASTOP®-CC firestop coating or PROMASEAL®-A firestop acrylic sealant on both sides of the penetration seal. In rigid floors PROMASTOP®-CC firestop coating or PROMASEAL®-A firestop acrylic sealant only needs to be applied on the bottom side of the floor.

*Classification depending on the separating element:*

Installation	Mineral wool board thicknesses (coated with PROMASTOP®-CC) and orientation					
	1 x 50 mm		1 x 80 mm		2 x 50 mm	
	Wall	Floor	Wall	Floor	Wall	Floor
All sheathed cable types: $\varnothing \leq 21$ mm	EI 60 E 90	EI 90 E 90	EI 90 E 90	EI 90 E 90	EI 120 E 120	EI 120 E 120
All sheathed cable types: $21 \text{ mm} \leq \varnothing \leq 50$ mm	EI 60 E 90	EI 60 E 90	EI 60 E 90	EI 90 E 90	EI 90 E 120	EI 90 E 120
All sheathed cable types: $50 \text{ mm} \leq \varnothing \leq 80$ mm	EI 60 E 90	EI 60 E 90	EI 60 E 90	EI 90 E 90	EI 90 E 120	EI 90 E 120
Tied cable bundle: $\varnothing \leq 100$ mm	EI 60 E 90	EI 90 E 90	EI 90 E 90	EI 90 E 90	EI 120 E 120	EI 120 E 120
All non-sheathed cable types: $\varnothing \leq 24$ mm	EI 45 E 90	EI 60 E 90	EI 60 E 90	EI 60 E 90	EI 90 E 120	EI 90 E 90
Small conduits and tubes, made of plastic or steel: $\varnothing \leq 16$ mm	EI 45 E 90	EI 45 E 90	EI 60 E 90	EI 60 E 90	EI 90 E 120	EI 90 E 90

*Thickness and length of PROMASTOP®-CC on cables, cable bundles, cable trays:*

Installation	Thickness (mm)	Length (mm)
All sheathed and non-sheathed cable types	1	100
Small conduits and tubes, made of plastic or steel $\varnothing \leq 16$ mm	3	
Cable trays and cable ladders (perforated or non-perforated)	1	

Cable trays and cable ladders may penetrate the penetration seal.

**3.3 Classification acc. to EN 13501-2 for the PROMASTOP®-CC firestop coating for metal pipes with non-combustible insulation**

Steel and copper pipes with non-combustible insulation may penetrate the PROMASTOP®-CC penetration seal.

*Specification of the non-combustible insulation:*  
See sections steel pipes and copper pipes.

The insulation shall be placed centered in the PROMASTOP®-CC penetration seal and fixed with steel wire (minimum thickness 0,6 mm).

The annular gap (max. width 10 mm) around the non-combustible insulation shall be sealed with PROMASTOP®-CC firestop coating or PROMASEAL®-A acrylic sealant and mineral wool (stone wool with a melting point  $\geq 1000^{\circ}\text{C}$ , class A1 acc. to EN 13501-1 and a minimum apparent density of  $40 \text{ kg/m}^3$ ) as backfilling material.

Metal pipes with mineral wool insulation according to following possibilities:

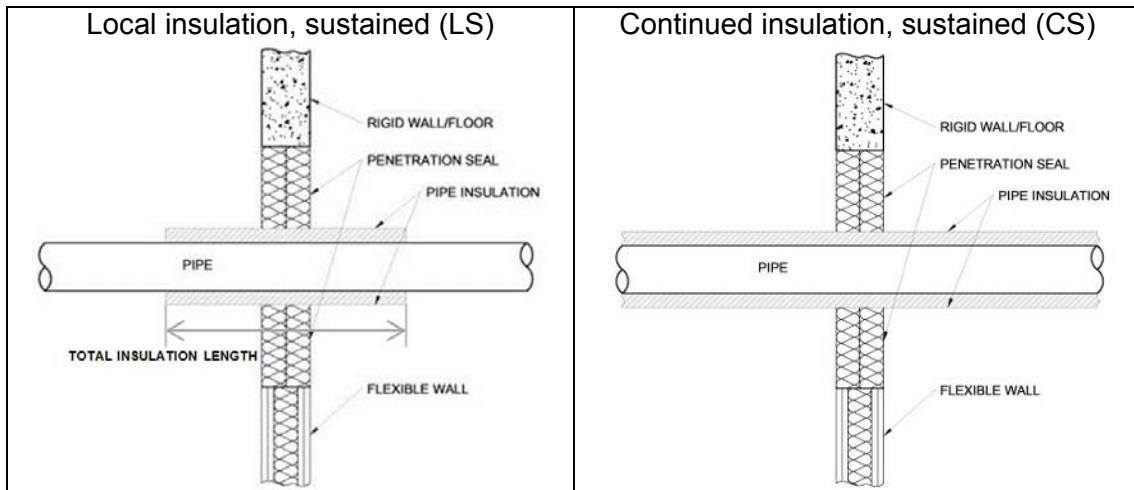

LS covers LS and CS.

**Steel pipes in 1 x 50 mm PROMASTOP®-CC penetration seal**

Specification Insulation	Thresholds
Stone wool	Melting point $\geq 1000^{\circ}\text{C}$ , reaction to fire minimum A2-s1, d0, A2 <sub>L</sub> -s1, d0 according to EN 13501-1
Density	$\geq 40 \text{ kg/m}^3$ to $\leq 150 \text{ kg/m}^3$
Insulation thickness	$\geq 30 \text{ mm}$ to $\leq 100 \text{ mm}$
Type of insulation	LS or CS
Length of insulation	See diagram below

Steel pipes with non-combustible insulation	Wall	Floor
Pipe diameter (mm)	$17 \leq 114$	$17 \leq 114$
Pipe wall thickness (mm)	$2,0 \leq 14,2$	$2,0 \leq 14,2$
Classification	<b>EI 60-U/C</b> <b>E 60-U/C</b>	<b>EI 60-U/C</b> <b>E 60-U/C</b>

For details see diagram below.

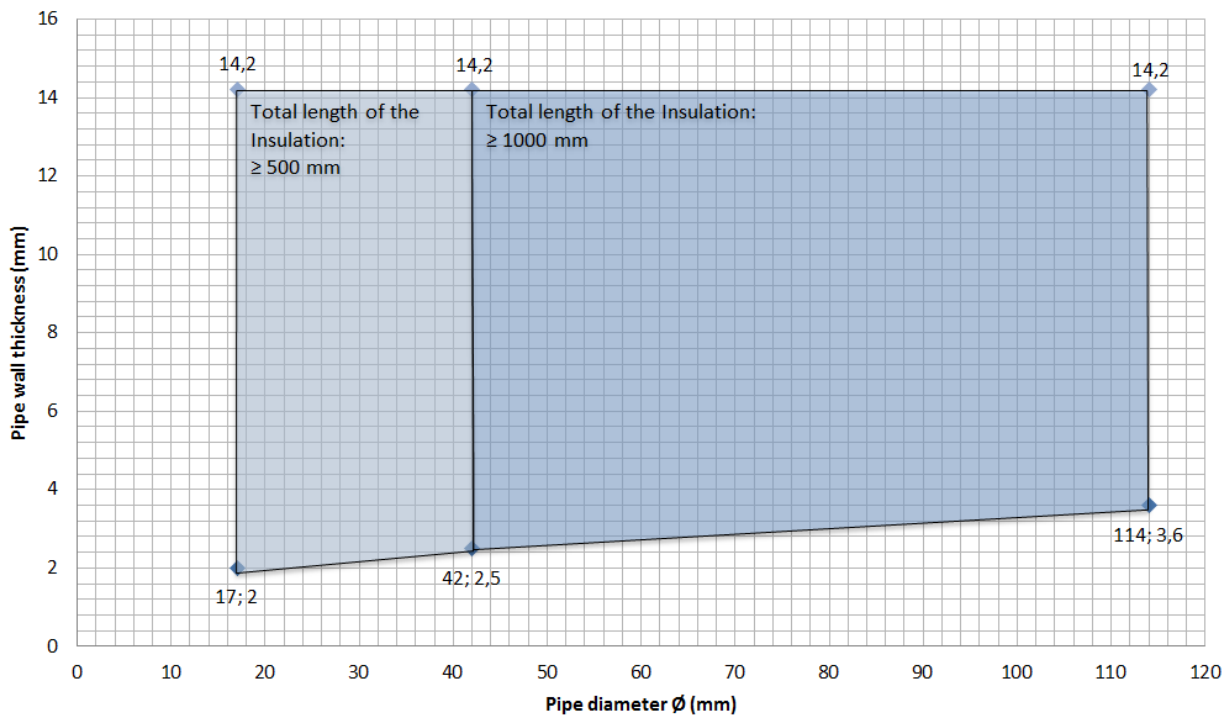

The field of application given for metal pipes with lower heat conductivity ( $\lambda \leq 58 \text{ W/mK}$ ) and a melting point of minimum  $1100^{\circ}\text{C}$  (e.g. stainless steel, cast iron, Ni alloys (NiCr, NiMo and NiCu alloys) and Ni.

### Steel pipes in 1 x 80 mm PROMASTOP®-CC penetration seal

Specification Insulation	Thresholds
Stone wool	Melting point $\geq 1000^{\circ}\text{C}$ , reaction to fire minimum A2-s1, d0, A2 <sub>L</sub> -s1, d0 according to EN 13501-1
Density	$\geq 40 \text{ kg/m}^3$ to $\leq 150 \text{ kg/m}^3$
Insulation thickness	$\geq 30 \text{ mm}$ to $\leq 100 \text{ mm}$
Type of insulation	LS or CS
Length of insulation	See diagram below

Steel pipes with non-combustible insulation	Wall	Floor
Pipe diameter (mm)	$17 \leq 114$	$17 \leq 114$
Pipe wall thickness (mm)	$2,0 \leq 14,2$	$2,0 \leq 14,2$
Classification	<b>EI 90-U/C</b> <b>E 90-U/C</b>	<b>EI 90-U/C</b> <b>E 90-U/C</b>

For details see diagram below.

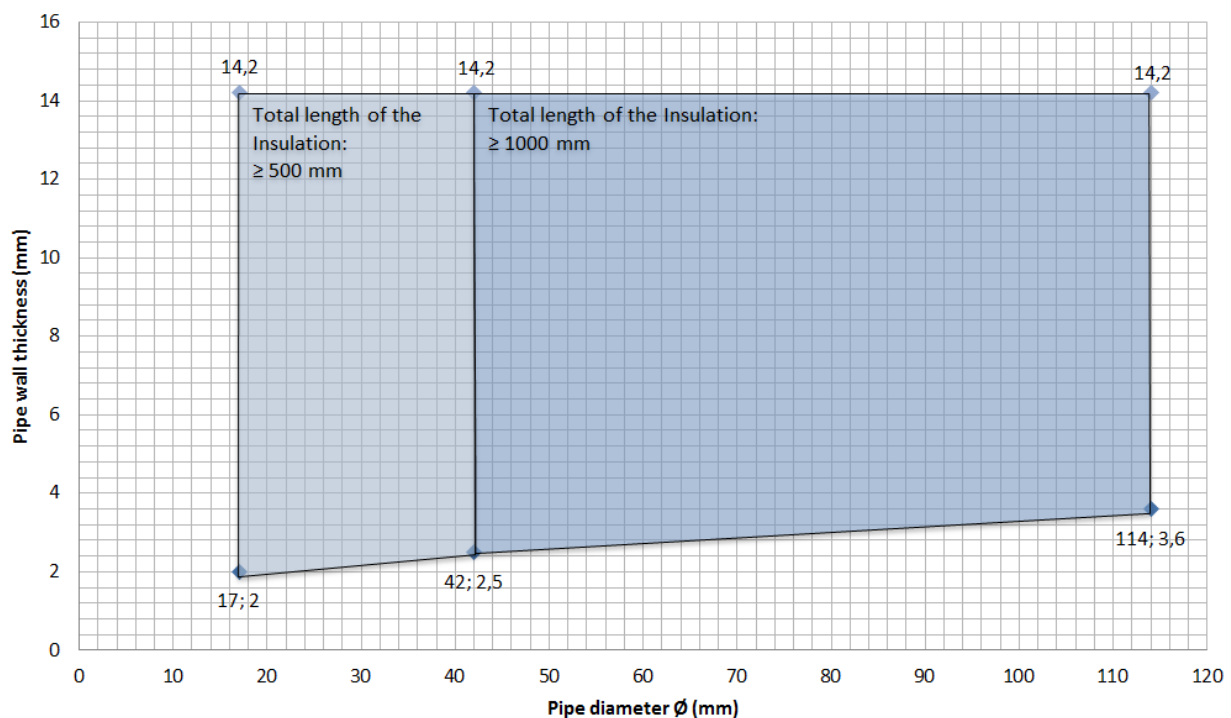

The field of application given for metal pipes with lower heat conductivity ( $\lambda \leq 58 \text{ W/mK}$ ) and a melting point of minimum  $1100^{\circ}\text{C}$  (e.g. stainless steel, cast iron, Ni alloys (NiCr, NiMo and NiCu alloys) and Ni).

**Steel pipes in 2 x 50 mm PROMASTOP®-CC penetration seal**

Specification Insulation	Thresholds
Stone wool	Melting point $\geq 1000^{\circ}\text{C}$ , reaction to fire minimum A2-s1, d0, A2 <sub>L</sub> -s1, d0 according to EN 13501-1
Density	$\geq 40 \text{ kg/m}^3$ to $\leq 150 \text{ kg/m}^3$
Insulation thickness	$\geq 30 \text{ mm}$ to $\leq 100 \text{ mm}$
Type of insulation	LS or CS
Length of insulation	See diagram below

Steel pipes with non-combustible insulation	Wall	Floor
Pipe diameter (mm)	$17 \leq 220$	$17 \leq 220$
Pipe wall thickness (mm)	$2,0 \leq 14,2$	$2,0 \leq 14,2$
Classification	<b>EI 90-U/C</b> <b>E 90-U/C</b>	<b>EI 90-U/C</b> <b>E 90-U/C</b>

For details see diagram below.

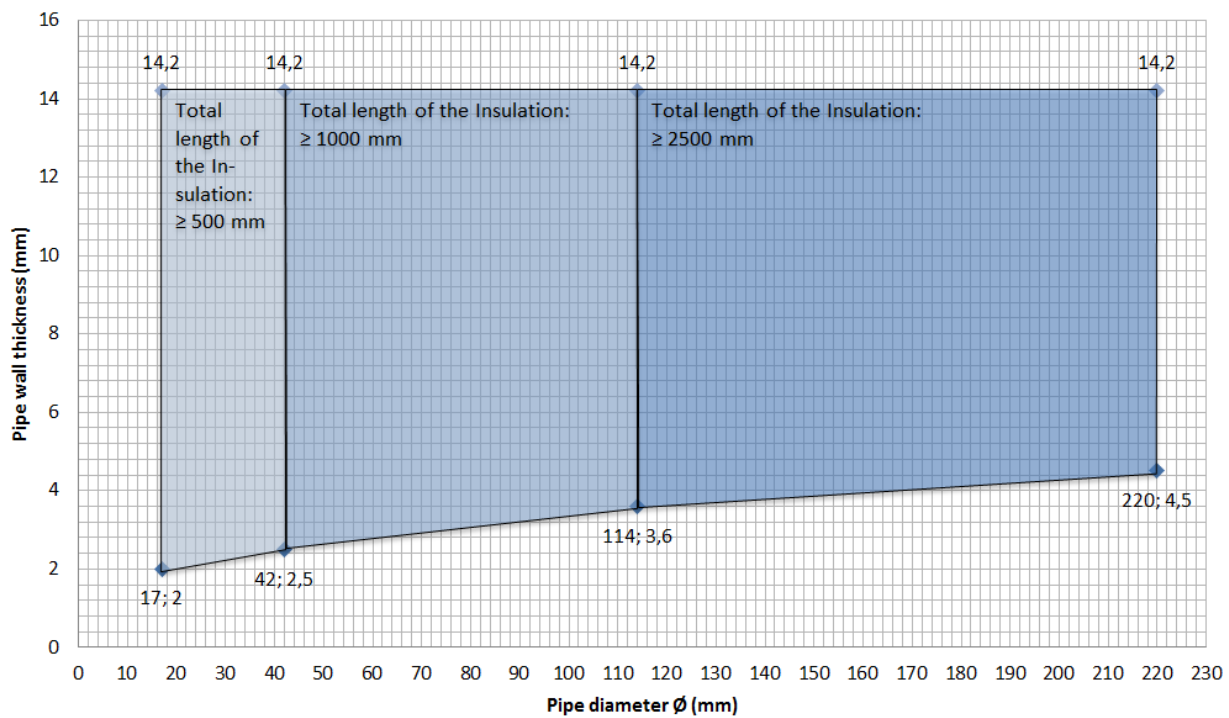

The field of application given for metal pipes with lower heat conductivity ( $\lambda \leq 58 \text{ W/mK}$ ) and a melting point of minimum  $1100^{\circ}\text{C}$  (e.g. stainless steel, cast iron, Ni alloys (NiCr, NiMo and NiCu alloys) and Ni.

**Steel pipes, Type Viega Sanpress, Viega Sanpress XL, Viega Sanpress Inox, Viega Sanpress Inox XL, Viega Sanpress Inox G, Viega Sanpress Inox G XL**

Specification Insulation	Thresholds
Stone wool	Melting point $\geq 1000^{\circ}\text{C}$ , reaction to fire minimum A2-s1, d0, A2L-s1, d0 according to EN 13501-1
Density	$\geq 80 \text{ kg/m}^3$ to $\leq 150 \text{ kg/m}^3$
Insulation thickness	$\geq 20 \text{ mm}$ to $\leq 100 \text{ mm}$
Type of insulation	LS or CS
Length of insulation	See diagram below

Steel pipes (Viega Sanpress, Viega Sanpress XL, Viega Sanpress Inox, Viega Sanpress Inox XL, Viega Sanpress Inox G, Viega Sanpress Inox G XL) with non-combustible insulation	Wall	Floor
Pipe diameter (mm)	$15 \leq 108$	$15 \leq 108$
Pipe wall thickness (th) (mm)	$1,0 \leq 14,2$	$1,0 \leq 14,2$
Classification	<b>EI 90-U/C</b> <b>E 90-U/C</b>	<b>EI 90-U/C</b> <b>E 90-U/C</b>

For details see diagram below.

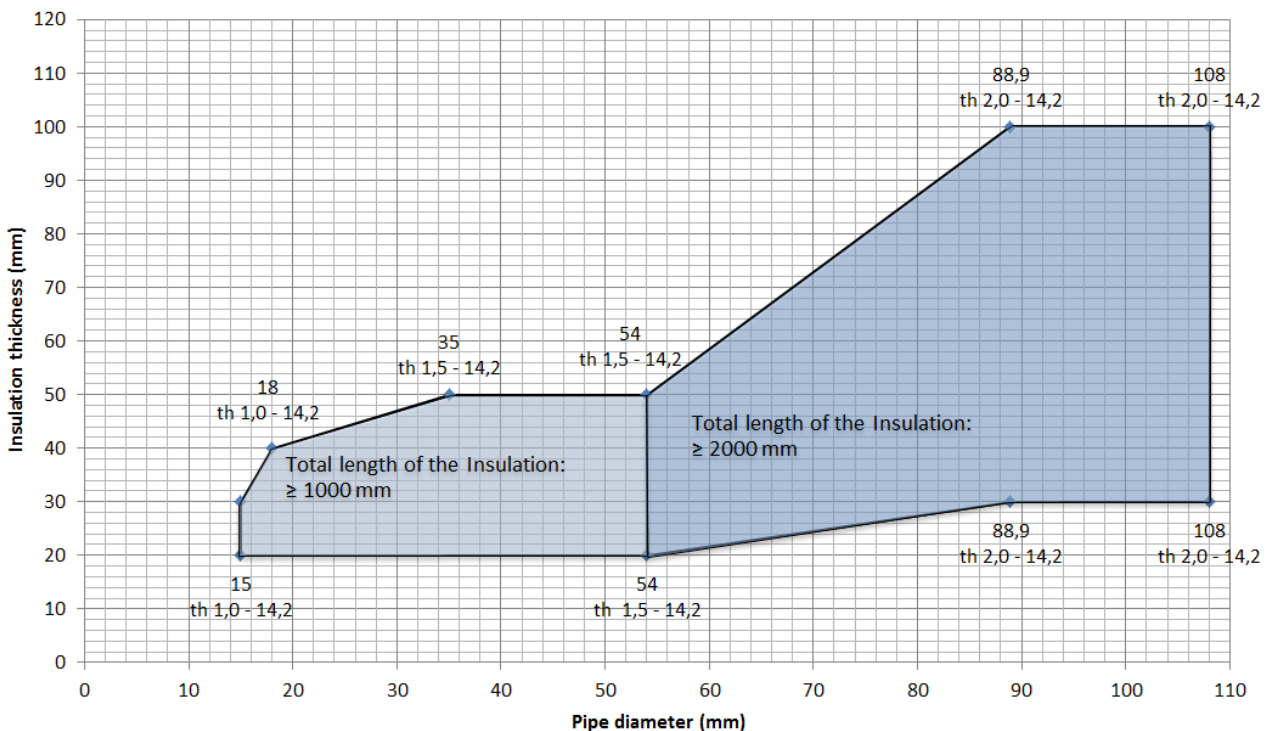

The field of application given for metal pipes with lower heat conductivity ( $\lambda \leq 58 \text{ W/mK}$ ) and a melting point of minimum  $1100^{\circ}\text{C}$  (e.g. stainless steel, cast iron, Ni alloys (NiCr, NiMo and NiCu alloys) and Ni.

**Copper pipes in 1 x 50 mm, 1 x 80 mm and 2 x 50 mm PROMASTOP®-CC penetration seal**

Specification Insulation	Thresholds
Stone wool	Melting point $\geq 1000^{\circ}\text{C}$ , reaction to fire minimum A2-s1, d0, A2 <sub>L</sub> -s1, d0 according to EN 13501-1
Density	$\geq 40 \text{ kg/m}^3$ to $\leq 150 \text{ kg/m}^3$
Insulation thickness	$\geq 30 \text{ mm}$ to $\leq 100 \text{ mm}$
Type of insulation	LS or CS
Length of insulation	See diagram below

Copper pipes with non-combustible insulation	Wall	Floor
Pipe diameter (mm)	$18 \leq 88,9$	$18 \leq 88,9$
Pipe wall thickness (mm)	$1,0 \leq 14,2$	$1,0 \leq 14,2$
Classification	<b>EI 90-U/C</b> <b>E 90-U/C</b>	<b>EI 90-U/C</b> <b>E 90-U/C</b>

For details see diagram below.

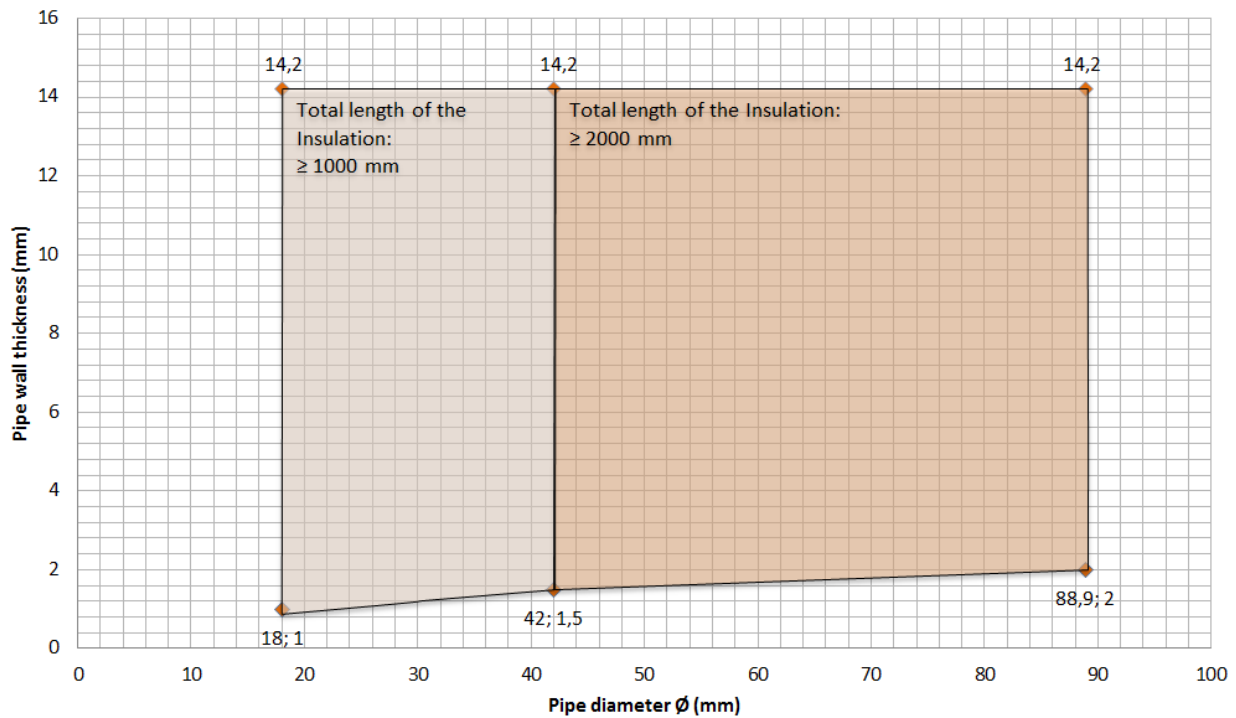

The field of application given for copper pipes is also valid for other metal pipes with lower heat conductivity ( $\lambda \leq 380 \text{ W/mK}$ ) and a melting point of minimum  $1083^{\circ}\text{C}$  (e.g. stainless steel, cast iron, Ni alloys (NiCr, NiMo and NiCu alloys) and Ni).

### 3.4 Classification acc. to EN 13501-2 for the PROMASTOP®-CC firestop coating and PROMASTOP®-W firestop wrap for metal pipes with combustible insulation

Steel and copper pipes with combustible insulation may penetrate the 2 x 50 mm PROMASTOP®-CC penetration seal. The firestop wrap PROMASTOP®-W shall be wrapped around the combustible insulation within the penetration seal (flushed to the surface of the penetration seal) and fixed by firestop coating PROMASTOP®-CC, the firestop acrylic sealant PROMASEAL®-A or the intumescent firestop sealant PROMASEAL®-AG.

*Application of the PROMASTOP®-W in the PROMASTOP®-CC penetration seal:*

Orientation	Application
Wall	On both sides of the penetration seal
Floor	On the bottom side of the penetration seal For Viega Sanpress, Viega Sanpress XL, Viega Sanpress Inox, Viega Sanpress Inox XL, Viega Sanpress Inox G, Viega Sanpress Inox G XL use one layer on the top and the bottom side of the penetration seal

*Specification of the combustible insulation:* See sections steel pipes and copper pipes

#### Steel pipes

Specification Insulation	Thresholds
Reaction to fire of the combustible insulation	Minimum B-s3, d0 according to EN 13501-1
Insulation thickness	≥ 6 mm to ≤ 32 mm
Type of insulation	LS or CS
Length of insulation	≥ 500 mm
One layer firestop wrap PROMASTOP®-W	

Steel pipes with combustible insulation	Wall	Floor
Pipe diameter (mm)	50 ≤ 220	50 ≤ 220
Pipe wall thickness (mm)	2,0 ≤ 14,2	1,0 ≤ 14,2
Classification	<b>EI 90-U/C</b> <b>E 90-U/C</b>	<b>EI 90-U/C</b> <b>E 90-U/C</b>

The field of application given for metal pipes with lower heat conductivity ( $\lambda \leq 58$  W/mK) and a melting point of minimum 1100°C (e.g. stainless steel, cast iron, Ni alloys (NiCr, NiMo and NiCu alloys) and Ni.

#### Steel pipes, Type Viega Sanpress, Viega Sanpress XL, Viega Sanpress Inox, Viega Sanpress Inox XL, Viega Sanpress Inox G, Viega Sanpress Inox G XL

Specification Insulation	Thresholds
Reaction to fire of the combustible insulation	Minimum B-s3,d0 according to EN 13501-1
Insulation thickness	≥ 9 mm to ≤ 32 mm
Type of insulation	CS
One layer firestop wrap PROMASTOP®-W	



Steel pipes (Viega Sanpress, Viega Sanpress XL, Viega Sanpress Inox, Viega Sanpress Inox XL, Viega Sanpress Inox G, Viega Sanpress Inox G XL) with combustible insulation	Wall	Floor
Pipe diameter (mm)	≤ 15	≤ 15
Pipe wall thickness (mm)	1,0 ≤ 14,2	1,0 ≤ 14,2
Classification	<b>EI 120-U/C</b> <b>E 120-U/C</b>	<b>EI 120-U/C</b> <b>E 120-U/C</b>
Pipe diameter (mm)	-	≤ 88,9
Pipe wall thickness (mm)	-	1,0 ≤ 14,2
Classification	-	<b>EI 60-U/C</b> <b>E 90-U/C</b>
Pipe diameter (mm)	≤ 108	-
Pipe wall thickness (mm)	1,0 ≤ 14,2	-
Classification	<b>EI 45-U/C</b> <b>E 90-U/C</b>	-

The field of application given for metal pipes with lower heat conductivity ( $\lambda \leq 58$  W/mK) and a melting point of minimum 1100°C (e.g. stainless steel, cast iron, Ni alloys (NiCr, NiMo and NiCu alloys) and Ni.

### Copper pipes

Specification Insulation	Thresholds
Reaction to fire of the combustible insulation	Minimum B-s3,d0 according to EN 13501-1
Insulation thickness	≥ 6 mm to ≤ 32 mm
Type of insulation	LS or CS
Length of insulation	≥ 500 mm
One layer firestop wrap PROMASTOP®-W	

Copper pipes with combustible insulation	Wall	Floor
Pipe diameter (mm)	20 ≤ 88,9	20 ≤ 88,9
Pipe wall thickness (mm)	2,0 ≤ 14,2	1,0 ≤ 14,2
Classification	<b>EI 90-U/C</b> <b>E 90-U/C</b>	<b>EI 90-U/C</b> <b>E 90-U/C</b>

The field of application given for copper pipes is also valid for other metal pipes with lower heat conductivity ( $\lambda \leq 380$  W/mK) and a melting point of minimum 1083°C (e.g. stainless steel, cast iron, Ni alloys (NiCr, NiMo and NiCu alloys) and Ni.

### 3.5 Classification acc. to EN 13501-2 for the PROMASTOP®-CC firestop coating and PROMASTOP®-W firestop wrap for aluminium-composite pipes Pipelife Radopress with combustible insulation (B-s3,d0 and E)

Plastic-Aluminium-Plastic (PE-Xb/Al/PE-HD) composite pipes (Pipelife Radopress) with combustible insulation may penetrate the 2 x 50 mm PROMASTOP®-CC penetration seal. The firestop wrap PROMASTOP®-W shall be wrapped around the combustible insulation within the penetration seal (flushed to the surface of the penetration seal) and fixed by firestop coating PROMASTOP®-CC, the firestop acrylic sealant PROMASEAL®-A or the intumescent firestop sealant PROMASEAL®-AG.

Application of the PROMASTOP®-W in the PROMASTOP®-CC penetration seal:

Orientation	Application
Wall	On both sides of the penetration seal
Floor	On the bottom side of the penetration seal

#### Pipelife Radopress pipes with class B-s3,d0 insulation

Specification Insulation	Thresholds
Reaction to fire of the combustible insulation	Minimum B-s3, d0 according to EN 13501-1
Insulation thickness	≥ 6 mm to ≤ 32 mm
Type of insulation	LS or CS
Length of insulation	≥ 500 mm
One layer firestop wrap PROMASTOP®-W	

Pipe Specification	Classification	
	Wall	Floor
<b>Pipelife Radopress</b> Ø 16 mm / t <sub>D</sub> 2,0 mm Ø 20 mm / t <sub>D</sub> 2,0 mm Ø 26 mm / t <sub>D</sub> 3,0 mm Ø 32 mm / t <sub>D</sub> 3,0 mm Ø 40 mm / t <sub>D</sub> 3,5 mm Ø 50 mm / t <sub>D</sub> 4,0 mm	<b>EI 120-U/C</b> <b>E 120-U/C</b>	<b>EI 120-U/C</b> <b>E 120-U/C</b>
<b>Pipelife Radopress</b> Ø 63 mm / t <sub>D</sub> 4,5 mm	<b>EI 120-U/C</b> <b>E 120-U/C</b>	<b>EI 60-U/C</b> <b>E 120-U/C</b>

#### Pipelife Radopress pipes with class E insulation

Specification of insulation	Thresholds
Reaction to fire of the combustible insulation	Minimum E according to EN 13501-1
Insulation thickness	≥ 4 mm to ≤ 9 mm
Type of insulation	CS
One layer firestop wrap PROMASTOP®-W	

Pipe Specification	Classification	
	Wall	Floor
<b>Pipelife Radopress</b> Ø 16 mm / t <sub>D</sub> 2,0 mm Ø 20 mm / t <sub>D</sub> 2,0 mm Ø 26 mm / t <sub>D</sub> 3,0 mm Ø 32 mm / t <sub>D</sub> 3,0 mm	<b>EI 120-U/C</b> <b>E 120-U/C</b>	<b>EI 120-U/C</b> <b>E 120-U/C</b>

**3.6 Classification acc. to EN 13501-2 for the PROMASTOP®-CC firestop coating and PROMASTOP®-FC firestop collar for aluminium-composite pipes Geberit Mepla with combustible insulation (B-s3,d0 and E)**

Plastic-Aluminium-Plastic (PE-RT II / Al / PE-RT II) composite pipes (Geberit Mepla) with combustible insulation may penetrate the 2 x 50 mm PROMASTOP®-CC penetration seal. The firestop collar PROMASTOP®-FC shall be placed around the combustible insulation on the penetration seal and fixed threaded rods.

*Application of the PROMASTOP®-FC on the PROMASTOP®-CC penetration seal:*

Orientation	Application
Wall	On both sides of the penetration seal

**Geberit Mepla pipes with class B-s3, d0 insulation**

Specification Insulation	Thresholds
Reaction to fire of the combustible insulation	Minimum B-s3, d0 according to EN 13501-1
Insulation thickness	≥ 6 mm to ≤ 32 mm
Type of insulation	LS or CS
Length of insulation	≥ 500 mm

Pipe Specification	Classification for 6 mm insulation	
	Wall	Floor
<b>Geberit Mepla</b> Ø 16 mm / t <sub>D</sub> 2,25 mm	<b>EI 120-U/C</b> <b>E 120-U/C</b>	-
<b>Geberit Mepla</b> Ø 20 mm / t <sub>D</sub> 2,5 mm Ø 26 mm / t <sub>D</sub> 3,0 mm	<b>EI 90-U/C</b> <b>E 90-U/C</b>	-
<b>Geberit Mepla</b> Ø 32 mm / t <sub>D</sub> 3,0 mm Ø 40 mm / t <sub>D</sub> 3,5 mm Ø 50 mm / t <sub>D</sub> 4,0 mm Ø 63 mm / t <sub>D</sub> 4,5 mm Ø 75 mm / t <sub>D</sub> 4,7 mm	<b>EI 60-U/C</b> <b>E 120-U/C</b>	-

Pipe Specification	Classification for 32 mm insulation	
	Wall	Floor
<b>Geberit Mepla</b> Ø 16 mm / t <sub>D</sub> 2,25 mm Ø 20 mm / t <sub>D</sub> 2,5 mm Ø 26 mm / t <sub>D</sub> 3,0 mm Ø 32 mm / t <sub>D</sub> 3,0 mm Ø 40 mm / t <sub>D</sub> 3,5 mm Ø 50 mm / t <sub>D</sub> 4,0 mm Ø 63 mm / t <sub>D</sub> 4,5 mm Ø 75 mm / t <sub>D</sub> 4,7 mm	<b>EI 90-U/C</b> <b>E 90-U/C</b>	-

**Geberit Mepla pipes with class E insulation**

Specification of insulation	Thresholds
Reaction to fire of the combustible insulation	Minimum E according to EN 13501-1
Insulation thickness	≤ 4 mm
Type of insulation	LS or CS
Length of insulation	≥ 200 mm

Pipe Specification	Classification	
	Wall	Floor
<b>Geberit Mepla</b> Ø 16 mm / t <sub>D</sub> 2,25 mm	<b>EI 120-U/C</b> <b>E 120-U/C</b>	-
<b>Geberit Mepla</b> Ø 20 mm / t <sub>D</sub> 2,5 mm Ø 26 mm / t <sub>D</sub> 3,0 mm Ø 32 mm / t <sub>D</sub> 3,0 mm Ø 40 mm / t <sub>D</sub> 3,5 mm Ø 50 mm / t <sub>D</sub> 4,0 mm Ø 63 mm / t <sub>D</sub> 4,5 mm Ø 75 mm / t <sub>D</sub> 4,7 mm	<b>EI 45-U/C</b> <b>E 120-U/C</b>	-

electronic copy

**3.7 Classification acc. to EN 13501-2 for the PROMASTOP®-CC firestop coating and aluminium-composite pipes Viega Raxofix and Viega Sanfix Fosta with non-combustible insulation (A2 / A2<sub>L</sub>)**

Plastic-Aluminium-Plastic (PE-Xc/Al/PE-Xc) composite pipes (Viega Raxofix and Viega Sanfix Fosta) with non-combustible insulation may penetrate the 2 x 50 mm PROMASTOP®-CC penetration seal.

*Specification of the non-combustible insulation:*  
See sections steel pipes and copper pipes.

The insulation shall be placed centered in the PROMASTOP®-CC penetration seal and fixed with steel wire (minimum thickness 0,6 mm).

The annular gap (max. width 10 mm) around the non-combustible insulation shall be sealed with PROMASTOP®-CC firestop coating or PROMASEAL®-A acrylic sealant and mineral wool (stone wool with a melting point  $\geq 1000^{\circ}\text{C}$ , class A1 acc. to EN 13501-1 and a minimum apparent density of  $40 \text{ kg/m}^3$ ) as backfilling material.

Specification Insulation	Thresholds
Stone wool	Melting point $\geq 1000^{\circ}\text{C}$ , reaction to fire minimum A2-s1, d0, A2 <sub>L</sub> -s1, d0 according to EN 13501-1
Density	$\geq 100 \text{ kg/m}^3$
Insulation thickness	$\geq 20 \text{ mm}$ to $\leq 50 \text{ mm}$
Type of insulation	LS or CS
Length of insulation (Minimum total insulation length)	For pipe diameter $\leq 40 \text{ mm}$ : $\geq 500 \text{ mm}$
	For pipe diameter $\leq 63 \text{ mm}$ : $\geq 1000 \text{ mm}$

Pipe Specification	Classification	
	Wall	Floor
<b>Viega Raxofix und Sanfix Fosta (PE-Xc/Al/PE-Xc)</b> $\varnothing 16 \text{ mm} / t_D 2,2 \text{ mm}$ $\varnothing 20 \text{ mm} / t_D 2,8 \text{ mm}$	<b>EI 120-U/C</b> <b>E 120-U/C</b>	-
<b>Viega Raxofix und Sanfix Fosta (PE-Xc/Al/PE-Xc)</b> $\varnothing 25 \text{ mm} / t_D 2,7 \text{ mm}$ $\varnothing 32 \text{ mm} / t_D 3,2 \text{ mm}$ $\varnothing 40 \text{ mm} / t_D 3,5 \text{ mm}$	<b>EI 120-U/C</b> <b>E 120-U/C</b>	<b>EI 90-U/C</b> <b>E 90-U/C</b>
<b>Viega Raxofix und Sanfix Fosta (PE-Xc/Al/PE-Xc)</b> $\varnothing 50 \text{ mm} / t_D 4,0 \text{ mm}$ $\varnothing 63 \text{ mm} / t_D 4,5 \text{ mm}$	<b>EI 120-U/C</b> <b>E 120-U/C</b>	-

**3.8 Classification acc. to EN 13501-2 for the PROMASTOP®-CC firestop coating and PROMASTOP®-W firestop wrap for aluminium-composite pipes Viega Raxofix and Viega Sanfix Fosta with combustible insulation (B-s3,d0)**

Plastic-Aluminium-Plastic (PE-Xc/Al/PE-Xc) composite pipes (Viega Raxofix and Viega Sanfix Fosta) with combustible insulation may penetrate the 2 x 50 mm PROMASTOP®-CC penetration seal. The firestop wrap PROMASTOP®-W shall be wrapped around the combustible insulation within the penetration seal (flushed to the surface of the penetration seal) and fixed by firestop coating PROMASTOP®-CC, the firestop acrylic sealant PROMASEAL®-A or the intumescent firestop sealant PROMASEAL®-AG.

*Application of the PROMASTOP®-W in the PROMASTOP®-CC penetration seal:*

Orientation	Application
Wall	On both sides of the penetration seal
Floor	On the top side and on the bottom side of the penetration seal

**Viega Raxofix and Viega Sanfix Fosta pipes with class B-s3,d0 insulation**

Specification Insulation	Thresholds
Reaction to fire of the combustible insulation	Minimum B-s3, d0 according to EN 13501-1
Insulation thickness	≥ 6 mm to ≤ 32 mm
Type of insulation	LS or CS
Length of insulation	≥ 500 mm
One layer firestop wrap PROMASTOP®-W	

Pipe Specification	Classification	
	Wall	Floor
<b>Viega Raxofix und Sanfix Fosta (PE-Xc/Al/PE-Xc)</b> Ø 16 mm / t <sub>D</sub> 2,2 mm	<b>EI 120-U/C</b> <b>E 120-U/C</b>	-
<b>Viega Raxofix und Sanfix Fosta (PE-Xc/Al/PE-Xc)</b> Ø 20 mm / t <sub>D</sub> 2,8 mm Ø 25 mm / t <sub>D</sub> 2,7 mm Ø 32 mm / t <sub>D</sub> 3,2 mm Ø 40 mm / t <sub>D</sub> 3,5 mm	<b>EI 120-U/C</b> <b>E 120-U/C</b>	<b>EI 90-U/C</b> <b>E 90-U/C</b>
<b>Viega Raxofix und Sanfix Fosta (PE-Xc/Al/PE-Xc)</b> Ø 50 mm / t <sub>D</sub> 4,0 mm Ø 63 mm / t <sub>D</sub> 4,5 mm	<b>EI 120-U/C</b> <b>E 120-U/C</b>	-

### 3.9 Classification acc. to EN 13501-2 for the PROMASTOP®-CC firestop coating and PROMASTOP®-W firestop wrap for PE-Xc pipes Viega Raxofix and Viega Sanfix with combustible insulation (B-s3,d0)

PE-Xc pipes (Viega Raxofix and Viega Sanfix) with combustible insulation may penetrate the 2 x 50 mm PROMASTOP®-CC penetration seal. The firestop wrap PROMASTOP®-W shall be wrapped around the combustible insulation within the penetration seal (flushed to the surface of the penetration seal) and fixed by firestop coating PROMASTOP®-CC, the firestop acrylic sealant PROMASEAL®-A or the intumescent firestop sealant PROMASEAL®-AG.

*Application of the PROMASTOP®-W in the PROMASTOP®-CC penetration seal:*

Orientation	Application
Wall	On both sides of the penetration seal
Floor	On the top side and on the bottom side of the penetration seal

#### Viega Raxofix and Viega Sanfix pipes with class B-s3,d0 insulation

Specification Insulation	Thresholds
Reaction to fire of the combustible insulation	Minimum B-s3, d0 according to EN 13501-1
Insulation thickness	≥ 6 mm to ≤ 32 mm
Type of insulation	LS or CS
Length of insulation	≥ 500 mm

No. of layers of PROMASTOP®-W	Pipe with Insulation
1	Raxofix / Sanfix Ø 16 – 20 mm with insulation 6 – 19 mm
2	Raxofix / Sanfix Ø 16 – 20 mm with insulation 25 – 32 mm

Pipe Specification	Classification	
	Wall	Floor
<b>Viega Raxofix (PE-Xc)</b> Ø 16 mm / t <sub>D</sub> 2,2 mm Ø 20 mm / t <sub>D</sub> 2,8 mm	<b>EI 120-U/C</b> <b>E 120-U/C</b>	<b>EI 120-U/C</b> <b>E 120-U/C</b>
<b>Viega Sanfix (PE-Xc)</b> Ø 16 mm / t <sub>D</sub> 2,2 mm Ø 20 mm / t <sub>D</sub> 2,8 mm	<b>EI 120-U/C</b> <b>E 120-U/C</b>	<b>EI 120-U/C</b> <b>E 120-U/C</b>

**3.10 Classification acc. to EN 13501-2 for the PROMASTOP®-CC firestop coating and PROMASTOP®-W firestop wrap for PE-Xc pipes Viega Raxofix and Viega Sanfix with combustible insulation (E)**

PE-Xc pipes (Viega Raxofix and Viega Sanfix) with combustible insulation may penetrate the 2 x 50 mm PROMASTOP®-CC penetration seal. The firestop wrap PROMASTOP®-W shall be wrapped around the combustible insulation within the penetration seal (flushed to the surface of the penetration seal) and fixed by firestop coating PROMASTOP®-CC, the firestop acrylic sealant PROMASEAL®-A or the intumescent firestop sealant PROMASEAL®-AG.

*Application of the PROMASTOP®-W in the PROMASTOP®-CC penetration seal:*

Orientation	Application
Wall	On both sides of the penetration seal
Floor	On the top side and on the bottom side of the penetration seal

**Viega Raxofix and Viega Sanfix pipes with class E insulation**

Specification Insulation	Thresholds
Reaction to fire of the combustible insulation	Minimum E according to EN 13501-1
Insulation thickness	≥ 4 mm to ≤ 13 mm
Type of insulation	CS
One layer firestop wrap PROMASTOP®-W	

Pipe Specification	Classification	
	Wall	Floor
<b>Viega Raxofix (PE-Xc)</b> Ø 16 mm / t <sub>D</sub> 2,2 mm Ø 20 mm / t <sub>D</sub> 2,8 mm	<b>EI 120-U/C</b> <b>E 120-U/C</b>	<b>EI 120-U/C</b> <b>E 120-U/C</b>
<b>Viega Sanfix (PE-Xc)</b> Ø 16 mm / t <sub>D</sub> 2,2 mm Ø 20 mm / t <sub>D</sub> 2,8 mm	<b>EI 120-U/C</b> <b>E 120-U/C</b>	<b>EI 120-U/C</b> <b>E 120-U/C</b>



**3.11 Classification acc. to EN 13501-2 for the PROMASTOP®-CC firestop coating and PROMASTOP®-W firestop wrap for PE-Xc pipes Viega Raxofix and Viega Sanfix**

PE-Xc pipes (Viega Raxofix and Viega Sanfix) may penetrate the 2 x 50 mm PROMASTOP®-CC penetration seal. The firestop wrap PROMASTOP®-W shall be wrapped around the pipes within the penetration seal (flushed to the surface of the penetration seal) and fixed by firestop coating PROMASTOP®-CC, the firestop acrylic sealant PROMASEAL®-A or the intumescent firestop sealant PROMASEAL®-AG.

*Application of the PROMASTOP®-W in the PROMASTOP®-CC penetration seal:*

Orientation	Application
Wall	On both sides of the penetration seal
Floor	On the bottom side of the penetration seal

**Viega Raxofix and Viega Sanfix pipes**

One layer firestop wrap PROMASTOP®-W

Pipe Specification	Classification	
	Wall	Floor
<b>Viega Raxofix (PE-Xc)</b> Ø 16 mm / t <sub>D</sub> 2,2 mm Ø 20 mm / t <sub>D</sub> 2,8 mm	<b>EI 120-U/C</b> <b>E 120-U/C</b>	<b>EI 120-U/C</b> <b>E 120-U/C</b>
<b>Viega Sanfix (PE-Xc)</b> Ø 16 mm / t <sub>D</sub> 2,2 mm Ø 20 mm / t <sub>D</sub> 2,8 mm	<b>EI 120-U/C</b> <b>E 120-U/C</b>	<b>EI 120-U/C</b> <b>E 120-U/C</b>

**3.12 Classification acc. to EN 13501-2 for the PROMASTOP®-CC firestop coating with PE-Xc pipes Viega Raxofix and Viega Sanfix with non-combustible insulation (A2 / A2<sub>L</sub>)**

PE-Xc pipes (Viega Raxofix and Viega Sanfix) with non-combustible insulation may penetrate the 2 x 50 mm PROMASTOP®-CC penetration seal.

The insulation shall be placed centered in the PROMASTOP®-CC penetration seal and fixed with steel wire (minimum thickness 0,6 mm).

The annular gap (max. width 10 mm) around the non-combustible insulation shall be sealed with PROMASTOP®-CC firestop coating or PROMASEAL®-A acrylic sealant and mineral wool (stone wool with a melting point  $\geq 1000^{\circ}\text{C}$ , class A1 acc. to EN 13501-1 and a minimum apparent density of  $40 \text{ kg/m}^3$ ) as backfilling material.

**Viega Raxofix and Viega Sanfix pipes with class A2 / A2<sub>L</sub> insulation**

Specification Insulation	Thresholds
Stone wool	Melting point $\geq 1000^{\circ}\text{C}$ , reaction to fire minimum A2-s1, d0, A2 <sub>L</sub> -s1, d0 according to EN 13501-1
Density	$\geq 100 \text{ kg/m}^3$
Insulation thickness	$\geq 20 \text{ mm}$ to $\leq 50 \text{ mm}$
Type of insulation	LS or CS
Length of insulation	$\geq 500 \text{ mm}$

Pipe Specification	Classification	
	Wall	Floor
<b>Viega Raxofix (PE-Xc)</b> Ø 16 mm / t <sub>D</sub> 2,2 mm Ø 20 mm / t <sub>D</sub> 2,8 mm	<b>EI 120-U/C</b> <b>E 120-U/C</b>	<b>EI 120-U/C</b> <b>E 120-U/C</b>
<b>Viega Sanfix (PE-Xc)</b> Ø 16 mm / t <sub>D</sub> 2,2 mm Ø 20 mm / t <sub>D</sub> 2,8 mm	<b>EI 120-U/C</b> <b>E 120-U/C</b>	<b>EI 120-U/C</b> <b>E 120-U/C</b>

**3.13 Classification acc. to EN 13501-2 for the PROMASTOP®-CC firestop coating and PROMASTOP®-W firestop wrap for plastic pipes**

Plastic pipes may penetrate the 2 x 50 mm PROMASTOP®-CC penetration seal. The firestop wrap PROMASTOP®-W shall be wrapped around the pipe within the penetration seal (flushed to the surface of the penetration seal) and fixed by firestop coating PROMASTOP®-CC, the firestop acrylic sealant PROMASEAL®-A or the intumescent firestop sealant PROMASEAL®-AG.

The number of layers depends on the pipe end configuration and pipe diameter.

*Application of the PROMASTOP®-W in the PROMASTOP®-CC penetration seal:*

Orientation	Application
Wall	On both sides of the penetration seal
Floor	On the bottom side of the penetration seal

Name of pipe	Dimension scope Ø...Diameter (mm) t <sub>p</sub> ...pipe wall thickness (mm)	Orien- tation Wall...W Floor...F	No. of Layers Ø (mm) → Layers	Classification
PVC-U	Ø 32 / t <sub>p</sub> 1,8 - Ø 160 / t <sub>p</sub> 11,8	W	32 – 63 → 1 75 – 110 → 2 125 → 3 140 – 160 → 4	<b>EI 120-U/C</b> <b>E 120-U/C</b>
PE-HD	Ø 32 / t <sub>p</sub> 2,0 - Ø 160 / t <sub>p</sub> 14,6	W	32 – 63 → 1 75 – 110 → 2 125 → 3 140 – 160 → 4	<b>EI 120-U/C</b> <b>E 120-U/C</b>
PP-H / PP-R	Ø 32 / t <sub>p</sub> 1,8 - Ø 160 / t <sub>p</sub> 14,6	W	32 – 63 → 1 75 – 110 → 2 125 → 3 140 – 160 → 4	<b>EI 120-U/C</b> <b>E 120-U/C</b>
Poloplast PoloKal NG	Ø 32 / t <sub>p</sub> 1,8 Ø 40 / t <sub>p</sub> 1,8 Ø 50 / t <sub>p</sub> 2,0 Ø 75 / t <sub>p</sub> 2,6 Ø 90 / t <sub>p</sub> 3,0 Ø 110 / t <sub>p</sub> 3,4 Ø 125 / t <sub>p</sub> 3,9 Ø 160 / t <sub>p</sub> 4,9	W	32 → 2 40 – 63 → 3 75 – 90 → 4 110 – 125 → 5 140 – 160 → 6	<b>EI 90-U/U</b> <b>E 90-U/U</b>
Poloplast PoloKal 3S	Ø 75 / t <sub>p</sub> 3,8 Ø 90 / t <sub>p</sub> 4,5 Ø 110 / t <sub>p</sub> 4,8 Ø 125 / t <sub>p</sub> 5,3 Ø 160 / t <sub>p</sub> 7,5	W	75 – 90 → 4 110 – 125 → 5 140 – 160 → 6	<b>EI 90-U/U</b> <b>E 90-U/U</b>
Poloplast PoloKal XS	Ø 32 / t <sub>p</sub> 1,8 Ø 40 / t <sub>p</sub> 1,8 Ø 50 / t <sub>p</sub> 2,0 Ø 75 / t <sub>p</sub> 2,6 Ø 90 / t <sub>p</sub> 3,0 Ø 110 / t <sub>p</sub> 3,4 Ø 125 / t <sub>p</sub> 3,9 Ø 160 / t <sub>p</sub> 4,9	W	32 → 2 40 – 63 → 3 75 – 90 → 4 110 – 125 → 5 140 – 160 → 6	<b>EI 90-U/U</b> <b>E 90-U/U</b>
Geberit Silent-db20	Ø 56 / t <sub>p</sub> 3,2 Ø 63 / t <sub>p</sub> 3,2 Ø 75 / t <sub>p</sub> 3,6 Ø 90 / t <sub>p</sub> 5,5 Ø 110 / t <sub>p</sub> 6,0 Ø 135 / t <sub>p</sub> 6,0 Ø 160 / t <sub>p</sub> 7,0	W	56 – 63 → 3 75 – 90 → 4 110 → 5 135 – 160 → 6	<b>EI 90-U/U</b> <b>E 90-U/U</b>

Name of pipe	Dimension scope Ø...Diameter (mm) t <sub>b</sub> ...pipe wall thickness (mm)	Orien- tation Wall...W Floor...F	No. of Layers Ø (mm) → Layers	Classification
PVC-U	Ø 32 / t <sub>b</sub> 1,8 - Ø 160 / t <sub>b</sub> 11,8	F	32 – 63 → 1 75 – 110 → 2 125 → 3 140 – 160 → 4	<b>EI 120-U/C</b> <b>E 120-U/C</b>
PE-HD	Ø 32 / t <sub>b</sub> 2,0 - Ø 160 / t <sub>b</sub> 14,6	F	32 – 63 → 1 75 – 110 → 2 125 → 3 140 – 160 → 4	<b>EI 120-U/C</b> <b>E 120-U/C</b>
PP-H / PP-R	Ø 32 / t <sub>b</sub> 1,8 - Ø 160 / t <sub>b</sub> 14,6	F	32 – 63 → 1 75 – 110 → 2 125 → 3 140 – 160 → 4	<b>EI 120-U/C</b> <b>E 120-U/C</b>
Poloplast PoloKal NG	Ø 32 / t <sub>b</sub> 1,8 Ø 40 / t <sub>b</sub> 1,8 Ø 50 / t <sub>b</sub> 2,0 Ø 75 / t <sub>b</sub> 2,6 Ø 90 / t <sub>b</sub> 3,0 Ø 110 / t <sub>b</sub> 3,4 Ø 125 / t <sub>b</sub> 3,9	F	32 → 2 40 – 63 → 3 75 – 90 → 4 110 – 125 → 5	<b>EI 90-U/U</b> <b>E 90-U/U</b>
Poloplast PoloKal XS	Ø 32 / t <sub>b</sub> 1,8 Ø 40 / t <sub>b</sub> 1,8 Ø 50 / t <sub>b</sub> 2,0 Ø 75 / t <sub>b</sub> 2,6 Ø 90 / t <sub>b</sub> 3,0 Ø 110 / t <sub>b</sub> 3,4 Ø 125 / t <sub>b</sub> 3,9	F	32 → 2 40 – 63 → 3 75 – 90 → 4 110 – 125 → 5	<b>EI 90-U/U</b> <b>E 90-U/U</b>
Geberit Silent-db20	Ø 56 / t <sub>b</sub> 3,2 Ø 63 / t <sub>b</sub> 3,2 Ø 75 / t <sub>b</sub> 3,6 Ø 90 / t <sub>b</sub> 5,5 Ø 110 / t <sub>b</sub> 6,0	F	63 → 3 75 – 90 → 4 110 → 5	<b>EI 90-U/U</b> <b>E 90-U/U</b>

The classifications for PVC-U pipes are applicable for pipes acc. to EN 1452-1, DIN 8061, DIN 8062.

The classifications for PE-HD pipes are applicable for pipes on acc. to EN 12201-2, DIN 8074, DIN 8075.

The classifications for PP-H and PP-R pipes are applicable for pipes acc. to EN ISO 15494, DIN 8077, DIN 8078.

PVC-U pipes with PROMASTOP®-W firestop wrap in the 2 x 50 mm PROMASTOP®-CC penetration seal  
in wall and floor, EI 120-U/C / E 120-U/C

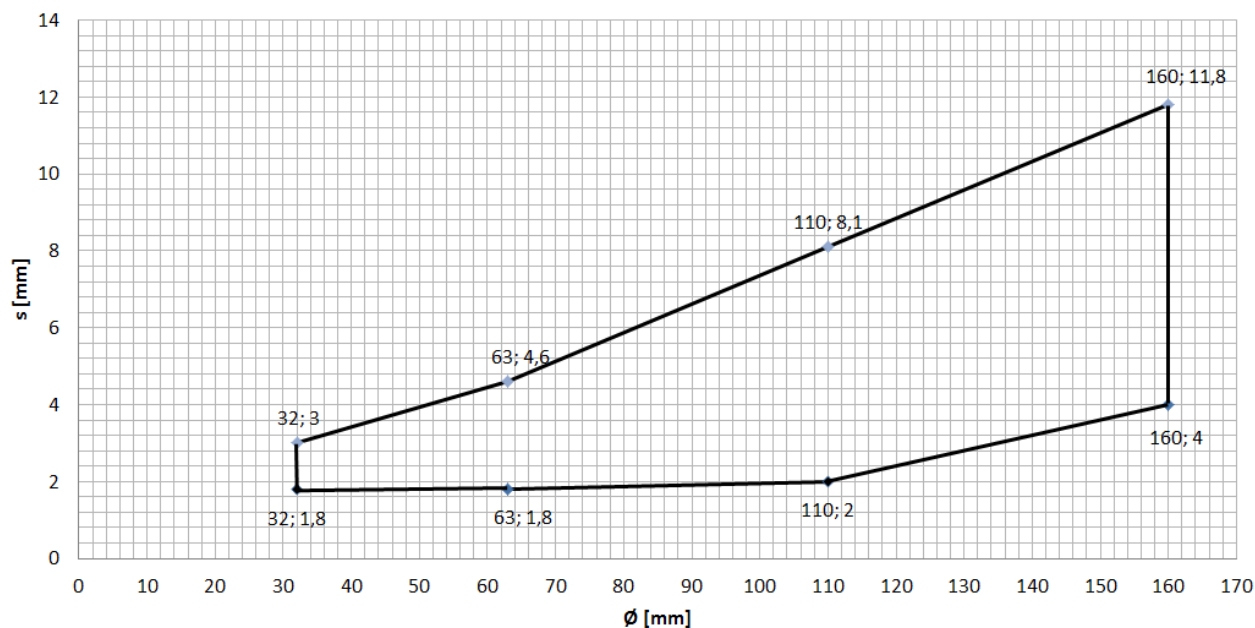

PE-HD pipes with PROMASTOP®-W firestop wrap in the 2 x 50 mm PROMASTOP®-CC penetration seal  
in wall and floor, EI 120-U/C / E 120-U/C

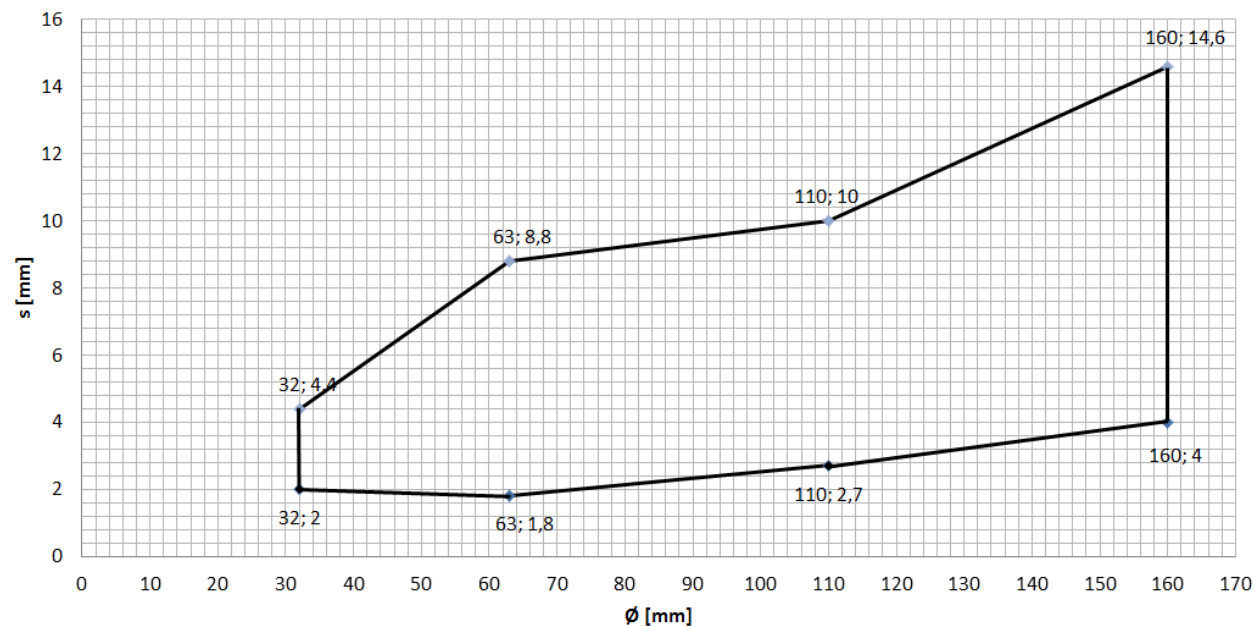

PP pipes with PROMASTOP®-W firestop wrap in the 2 x 50 mm PROMASTOP®-CC penetration seal in wall and floor, EI 120-U/C / E 120-U/C

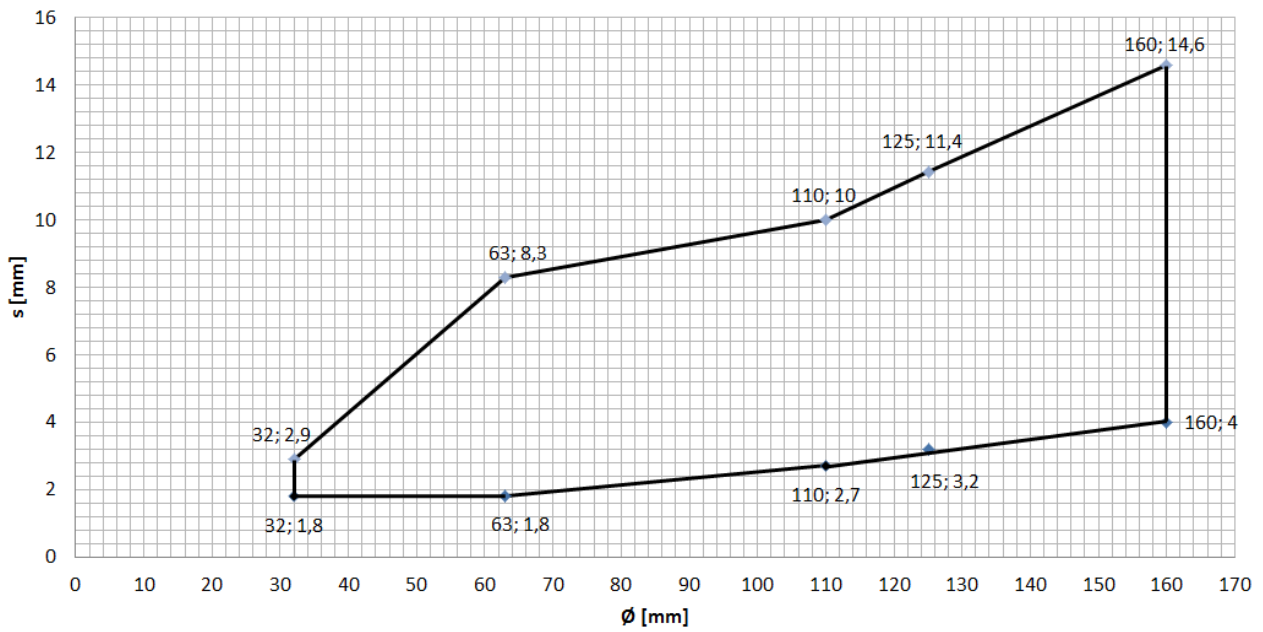

### 3.14 Classification acc. to EN 13501-2 for the PROMASTOP®-CC firestop coating and PROMASTOP®-FC firestop collar for plastic pipes

Plastic pipes may penetrate the 1 x 50 mm, 1 x 80 mm and 2 x 50 mm PROMASTOP®-CC penetration seal.

The smallest pipe collar corresponding to the relevant outer diameter of the pipe to be sealed off shall be used. The number of fastening hooks shall not be reduced.

The firestop collar PROMASTOP®-FC shall be fixed by threaded steel rods (M6 or M8) with nuts and washers. For the built in situation the hooks of the collars are placed between the mineral wool boards.

The annular gap (max. width 16 mm) between the plastic pipe and the mineral wool board shall be filled with mineral wool (stone wool with a melting point  $\geq 1000^{\circ}\text{C}$ , class A1 acc. to EN 13501-1 and a minimum apparent density of  $40 \text{ kg/m}^3$ ) and afterwards coated with PROMASTOP®-CC firestop coating or PROMASEAL®-A firestop acrylic sealant on both sides of the penetration seal. In rigid floors PROMASTOP®-CC firestop coating or PROMASEAL®-A firestop acrylic sealant only needs to be applied on the bottom side of the floor.

*Application of the PROMASTOP®-FC in the PROMASTOP®-CC penetration seal:*

Orientation	Application
Wall	On both sides of the penetration seal
Floor	On the bottom side of the penetration seal

*The firestop collar is supplied in several sizes and two heights:*

Name	Height of the collar
PROMASTOP®-FC3	30 mm
PROMASTOP®-FC6	60 mm

*Sound decoupling:*

Sound decoupling (e.g. Kaiflex PE-AB Abflusisolierung from manufacturer Kaiman) based on PE (closed-cell elastomeric foam, maximum thickness 5 mm, class E acc. to EN 13501-1, maximum one layer) may be used (only to be used for plastic pipes).

*Couplings:*

On pipe couplings the fire stop collar PROMASTOP®-FC6 shall be used. The diameter of the tested couplings can be reduced, but not increased.

*Specification of the plastic pipes:* See section below

Name	Dimension scope $\varnothing$ ...Diameter (mm) $t_b$ ...pipe wall thickness (mm)	Orien- tation Wall...W Floor...F	Collar type	Seal type (Number of boards x thickness in mm)	Classification
Friatec Friaphon	$\varnothing 52 / t_b 2,8 - \varnothing 110 / t_b 5,3$	F	FC3	1 x 50	<b>EI 60-U/U</b> <b>E 60-U/U</b>
		F	FC3	1 x 80	<b>EI 90-U/U</b> <b>E 90-U/U</b>
		F	FC3	2 x 50	<b>EI 90-U/U</b> <b>E 90-U/U</b>

Name	Dimension scope Ø...Diameter (mm) t <sub>D</sub> ...pipe wall thickness (mm)	Orien- tation Wall...W Floor...F	Collar type	Seal type (Number of boards x thickness in mm)	Classification
Friatec dBlue	Ø 50 / t <sub>D</sub> 1,8 - Ø 125 / t <sub>D</sub> 3,9	F	FC3	1 x 50	EI 60-U/U E 60-U/U
		F	FC3	1 x 80	EI 90-U/U E 90-U/U
		F	FC3	2 x 50	EI 90-U/U E 90-U/U
Geberit Silent-db20	Ø 56 / t <sub>D</sub> 3,2 - Ø 160 / t <sub>D</sub> 7,0	F	FC3	1 x 50	EI 60-U/U E 60-U/U
		F	FC3	1 x 80	EI 90-U/U E 90-U/U
		F	FC3	2 x 50	EI 90-U/U E 90-U/U
Geberit Silent-db20	Ø 56 / t <sub>D</sub> 3,2 - Ø 135 / t <sub>D</sub> 6,0	W	FC3	1 x 50	EI 60-U/U E 60-U/U
		W	FC3	1 x 80	EI 90-U/U E 90-U/U
		W	FC3	2 x 50	EI 90-U/U E 90-U/U
Geberit Silent-PP	Ø 32 / t <sub>D</sub> 2,0 - Ø 125 / t <sub>D</sub> 4,2	F	FC3	1 x 50	EI 60-U/U E 60-U/U
		F	FC3	1 x 80	EI 90-U/U E 90-U/U
		F	FC3	2 x 50	EI 90-U/U E 90-U/U
Pipelife Master3	Ø 75 / t <sub>D</sub> 2,1 - Ø 125 / t <sub>D</sub> 3,5	F	FC3	1 x 50	EI 60-U/U E 60-U/U
		F	FC3	1 x 80	EI 90-U/U E 90-U/U
		F	FC3	2 x 50	EI 90-U/U E 90-U/U
Pipelife Master3	Ø 75 / t <sub>D</sub> 2,1 - Ø 125 / t <sub>D</sub> 3,5	W	FC3	1 x 50	EI 60-U/U E 60-U/U
		W	FC3	1 x 80	EI 90-U/U E 90-U/U
		W	FC3	2 x 50	EI 120-U/U E 120-U/U
Poloplast PoloKal NG	Ø 32 / t <sub>D</sub> 1,8 - Ø 250 / t <sub>D</sub> 8,6	F	FC3/6	1 x 50	EI 60-U/U E 60-U/U
		F	FC3/6	1 x 80	EI 90-U/U E 90-U/U
		F	FC3/6	2 x 50	EI 90-U/U E 90-U/U
Poloplast PoloKal NG	Ø 32 / t <sub>D</sub> 1,8 - Ø 250 / t <sub>D</sub> 8,6	W	FC3/6	1 x 50	EI 60-U/U E 60-U/U
		W	FC3/6	1 x 80	EI 90-U/U E 90-U/U
		W	FC3/6	2 x 50	EI 90-U/U E 90-U/U
Poloplast PoloKal NG	Ø 32 / t <sub>D</sub> 1,8 - Ø 160 / t <sub>D</sub> 4,9	W	FC3	2 x 50	EI 120-U/U E 120-U/U
Poloplast PoloKal 3S	Ø 75 / t <sub>D</sub> 3,8 - Ø 160 / t <sub>D</sub> 7,5	F	FC3	1 x 50	EI 60-U/U E 60-U/U
		F	FC3	1 x 80	EI 90-U/U E 90-U/U
		F	FC3	2 x 50	EI 90-U/U E 90-U/U



Name	Dimension scope Ø...Diameter (mm) t <sub>b</sub> ...pipe wall thickness (mm)	Orien- tation Wall...W Floor...F	Collar type	Seal type (Number of boards x thickness in mm)	Classification
Poloplast PoloKal 3S	Ø 75 / t <sub>b</sub> 3,8 - Ø 160 / t <sub>b</sub> 7,5	W	FC3	1 x 50	EI 60-U/U E 60-U/U
		W	FC3	1 x 80	EI 90-U/U E 90-U/U
		W	FC3	2 x 50	EI 120-U/U E 120-U/U
Poloplast PoloKal XS	Ø 32 / t <sub>b</sub> 1,8 - Ø 250 / t <sub>b</sub> 8,6	F	FC3/6	1 x 50	EI 60-U/U E 60-U/U
		F	FC3/6	1 x 80	EI 90-U/U E 90-U/U
		F	FC3/6	2 x 50	EI 90-U/U E 90-U/U
Poloplast PoloKal XS	Ø 32 / t <sub>b</sub> 1,8 - Ø 250 / t <sub>b</sub> 8,6	W	FC3/6	1 x 50	EI 60-U/U E 60-U/U
		W	FC3/6	1 x 80	EI 90-U/U E 90-U/U
		W	FC3/6	2 x 50	EI 90-U/U E 90-U/U
Poloplast PoloKal XS	Ø 32 / t <sub>b</sub> 1,8 - Ø 160 / t <sub>b</sub> 4,9	W	FC3	2 x 50	EI 120-U/U E 120-U/U
PVC-U	Ø 32 / t <sub>b</sub> 1,8 - Ø 250 / t <sub>b</sub> 4,9	F	FC3/6	1 x 50	EI 60-U/U E 60-U/U
		F	FC3/6	1 x 80	EI 90-U/U E 90-U/U
		F	FC3/6	2 x 50	EI 90-U/U E 90-U/U
PVC-U	Ø 125 / t <sub>b</sub> 3,2 - Ø 160 / t <sub>b</sub> 3,6	F (built in)	FC3/6	2 x 50	EI 90-U/U E 90-U/U
PE-HD	Ø 32 / t <sub>b</sub> 1,8 - Ø 200 / t <sub>b</sub> 11,4	F	FC3/6	1 x 50	EI 60-U/U E 60-U/U
		F	FC3/6	1 x 80	EI 90-U/U E 90-U/U
		F	FC3/6	2 x 50	EI 90-U/U E 90-U/U
PE-HD	Ø 40 / t <sub>b</sub> 1,8 - Ø 200 / t <sub>b</sub> 11,4	W	FC3/6	1 x 50	EI 60-U/U E 60-U/U
		W	FC3/6	1 x 80	EI 90-U/U E 90-U/U
		W	FC3/6	2 x 50	EI 90-U/U E 90-U/U
PE-HD	Ø 40 / t <sub>b</sub> 1,8 - Ø 200 / t <sub>b</sub> 11,4	W (built in)	FC3/6	2 x 50	EI 90-U/U E 90-U/U
PP-H / PP-R	Ø 32 / t <sub>b</sub> 1,8 - Ø 200 / t <sub>b</sub> 11,4	F	FC3/6	1 x 50	EI 60-U/U E 60-U/U
		F	FC3/6	1 x 80	EI 90-U/U E 90-U/U
		F	FC3/6	2 x 50	EI 90-U/U E 90-U/U
PP-H / PP-R	Ø 40 / t <sub>b</sub> 1,8 - Ø 250 / t <sub>b</sub> 14,2	W	FC3/6	1 x 50	EI 60-U/U E 60-U/U
		W	FC3/6	1 x 80	EI 90-U/U E 90-U/U
		W	FC3/6	2 x 50	EI 90-U/U E 90-U/U

Name	Dimension scope Ø...Diameter (mm) t <sub>D</sub> ...pipe wall thickness (mm)	Orien- tation Wall...W Floor...F	Collar type	Seal type (Number of boards x thickness in mm)	Classification
PP-H / PP-R	Ø 75 / t <sub>D</sub> 2,6 - Ø 90 / t <sub>D</sub> 3,0	F (built in)	FC3/6	2 x 50	<b>EI 90-U/U</b> <b>E 90-U/U</b>
PP-H / PP-R	Ø 40 / t <sub>D</sub> 1,8 - Ø 250 / t <sub>D</sub> 14,2	W	FC6	2 x 50	<b>EI 120-U/U</b> <b>E 120-U/U</b>
Rehau Raupiano Plus	Ø 40 / t <sub>D</sub> 1,8 - Ø 200 / t <sub>D</sub> 6,2	F	FC6	1 x 50	<b>EI 60-U/U</b> <b>E 60-U/U</b>
		F	FC6	1 x 80	<b>EI 90-U/U</b> <b>E 90-U/U</b>
		F	FC6	2 x 50	<b>EI 90-U/U</b> <b>E 90-U/U</b>
Rehau Raupiano Plus (+coupling)	Ø 40 / t <sub>D</sub> 1,8 - Ø 125 / t <sub>D</sub> 3,1	F	FC6	1 x 50	<b>EI 60-U/U</b> <b>E 60-U/U</b>
		F	FC6	1 x 80	<b>EI 90-U/U</b> <b>E 90-U/U</b>
		F	FC6	2 x 50	<b>EI 90-U/U</b> <b>E 90-U/U</b>
Rehau Raupiano Plus (+coupling)	Ø 40 / t <sub>D</sub> 1,8 - Ø 125 / t <sub>D</sub> 3,1	W	FC6	1 x 50	<b>EI 60-U/U</b> <b>E 60-U/U</b>
		W	FC6	1 x 80	<b>EI 90-U/U</b> <b>E 90-U/U</b>
		W	FC6	2 x 50	<b>EI 120-U/U</b> <b>E 120-U/U</b>

Details are shown in the following diagrams. In the diagrams the pipe outer diameter is stated.

The classifications for PVC-U pipes are applicable for pipes acc. to EN 1452-1, DIN 8061, DIN 8062.

The classifications for PE-HD pipes are applicable for pipes on acc. to EN 12201-2, DIN 8074, DIN 8075.

The classifications for PP-H and PP-R pipes are applicable for pipes acc. to EN ISO 15494, DIN 8077, DIN 8078.

### Classification details

Friatec Friaphon	Ø 52 / t <sub>D</sub> 2,8 - Ø 110 / t <sub>D</sub> 5,3	Floor	FC3	1 x 50	EI 60-U/U E 60-U/U
		Floor	FC3	1 x 80	EI 90-U/U E 90-U/U
		Floor	FC3	2 x 50	EI 90-U/U E 90-U/U

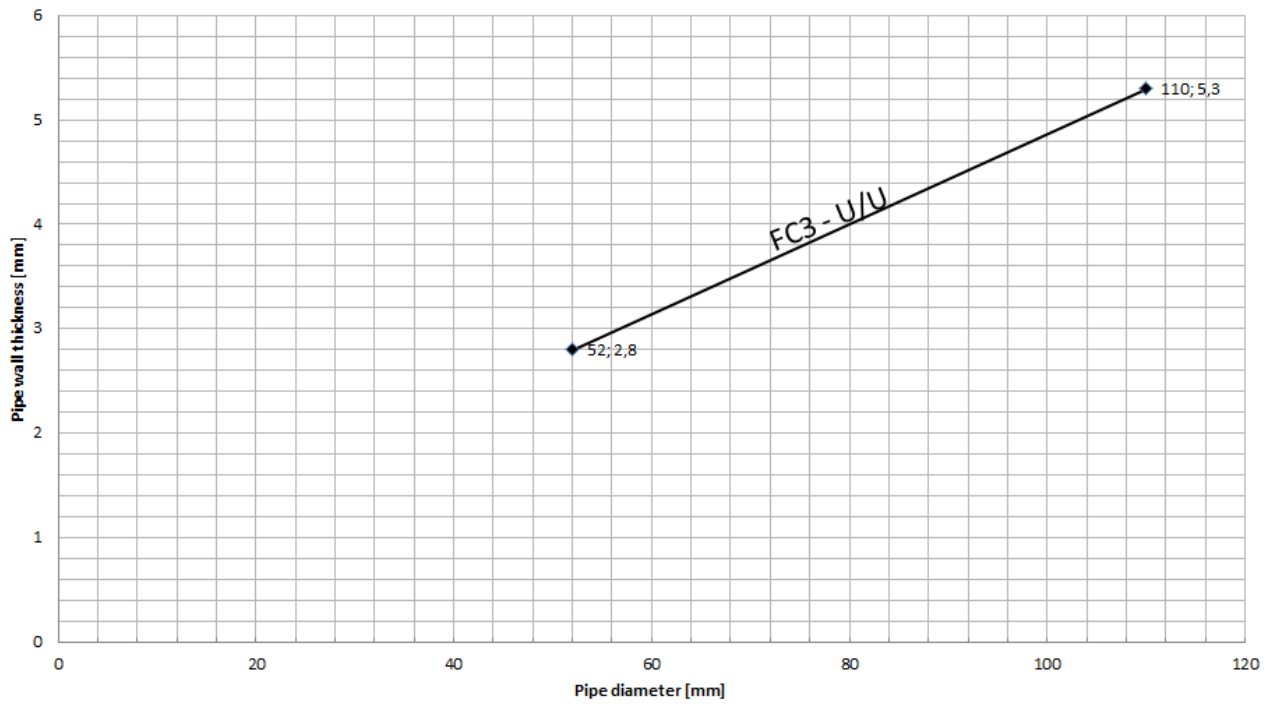

Friatec dBlue	Ø 50 / t <sub>D</sub> 1,8 - Ø 125 / t <sub>D</sub> 3,9	Floor	FC3	1 x 50	EI 60-U/U E 60-U/U
		Floor	FC3	1 x 80	EI 90-U/U E 90-U/U
		Floor	FC3	2 x 50	EI 90-U/U E 90-U/U

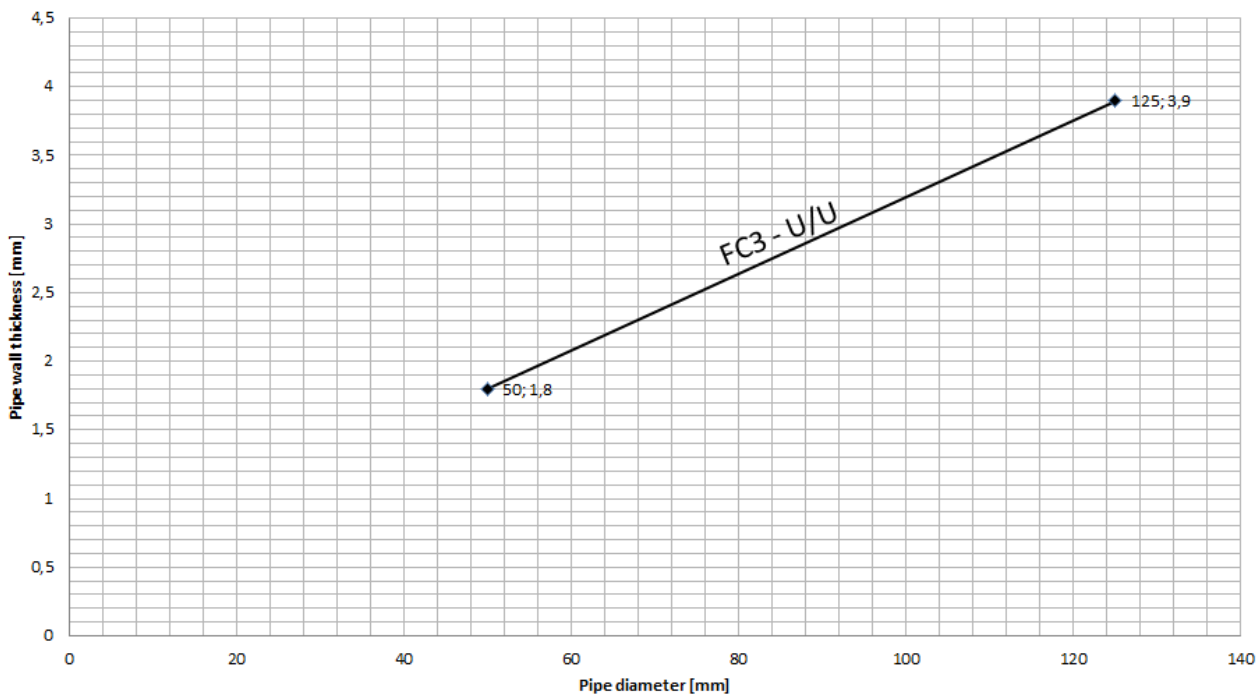

Geberit Silent-db20	Ø 56 / t <sub>D</sub> 3,2 - Ø 160 / t <sub>D</sub> 7,0	Floor	FC3	1 x 50	EI 60-U/U E 60-U/U
		Floor	FC3	1 x 80	EI 90-U/U E 90-U/U
		Floor	FC3	2 x 50	EI 90-U/U E 90-U/U

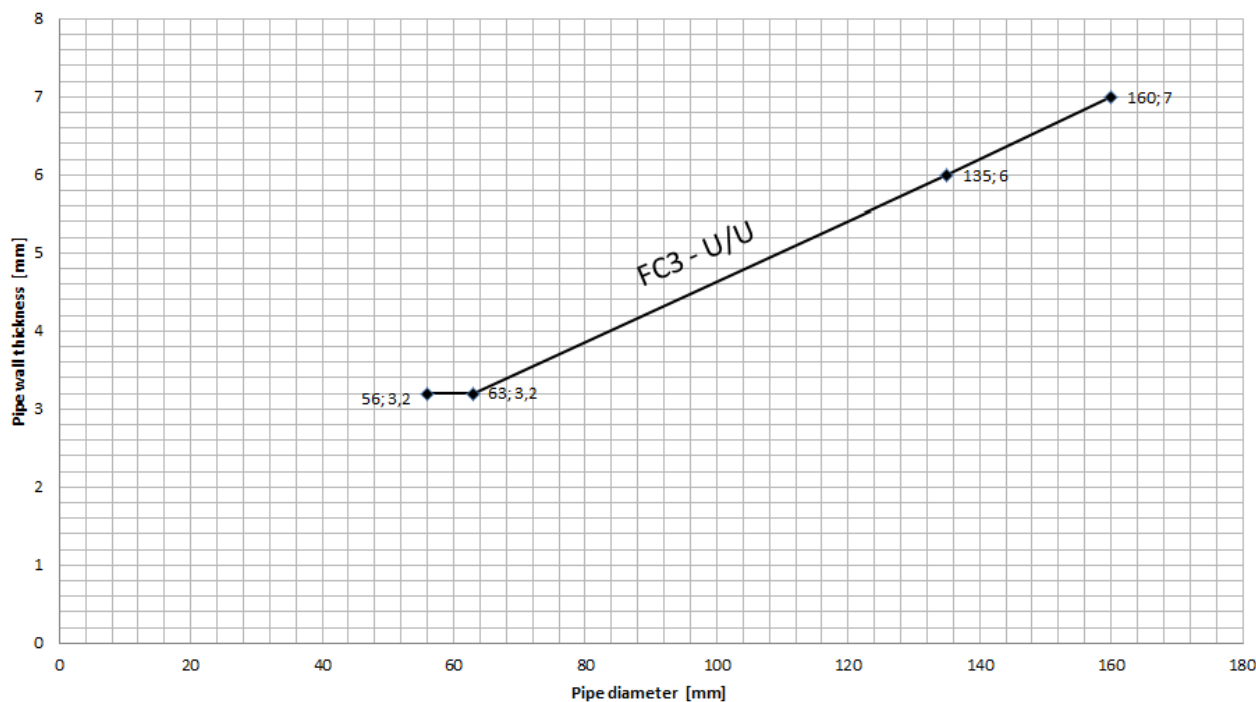

Geberit Silent-PP	Ø 32 / t <sub>b</sub> 2,0 - Ø 125 / t <sub>b</sub> 4,2	Floor	FC3	1 x 50	EI 60-U/U E 60-U/U
		Floor	FC3	1 x 80	EI 90-U/U E 90-U/U
		Floor	FC3	2 x 50	EI 90-U/U E 90-U/U

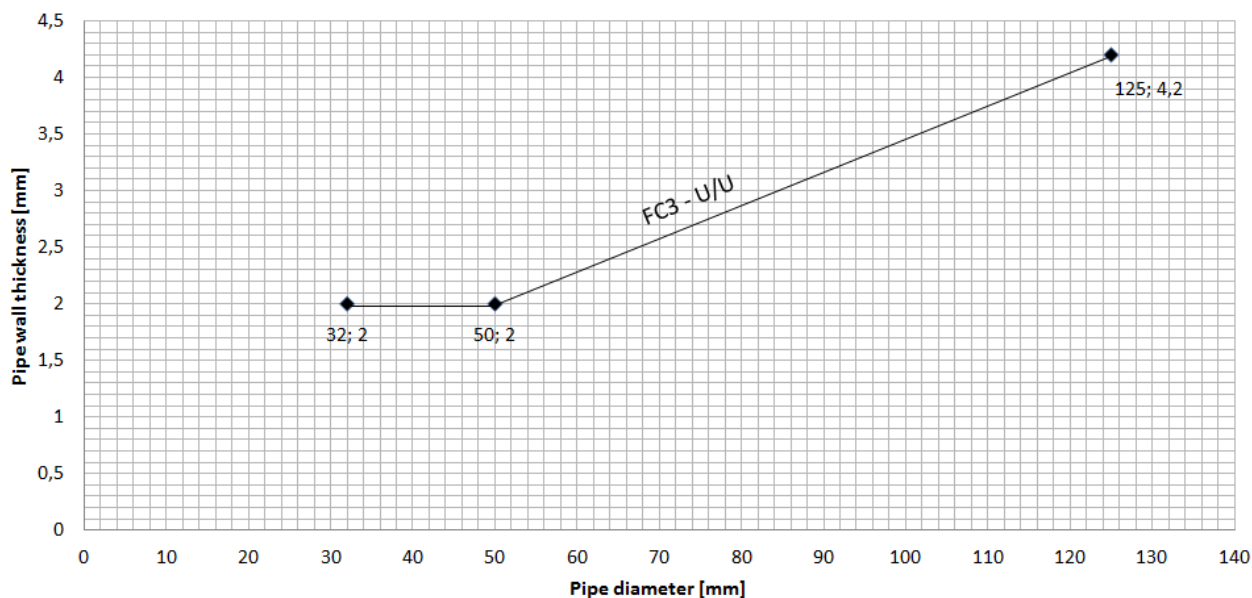

Geberit Silent-db20	Ø 56 / t <sub>b</sub> 3,2 - Ø 135 / t <sub>b</sub> 6,0	Wall	FC3	1 x 50	EI 60-U/U E 60-U/U
		Wall	FC3	1 x 80	EI 90-U/U E 90-U/U
		Wall	FC3	2 x 50	EI 90-U/U E 90-U/U

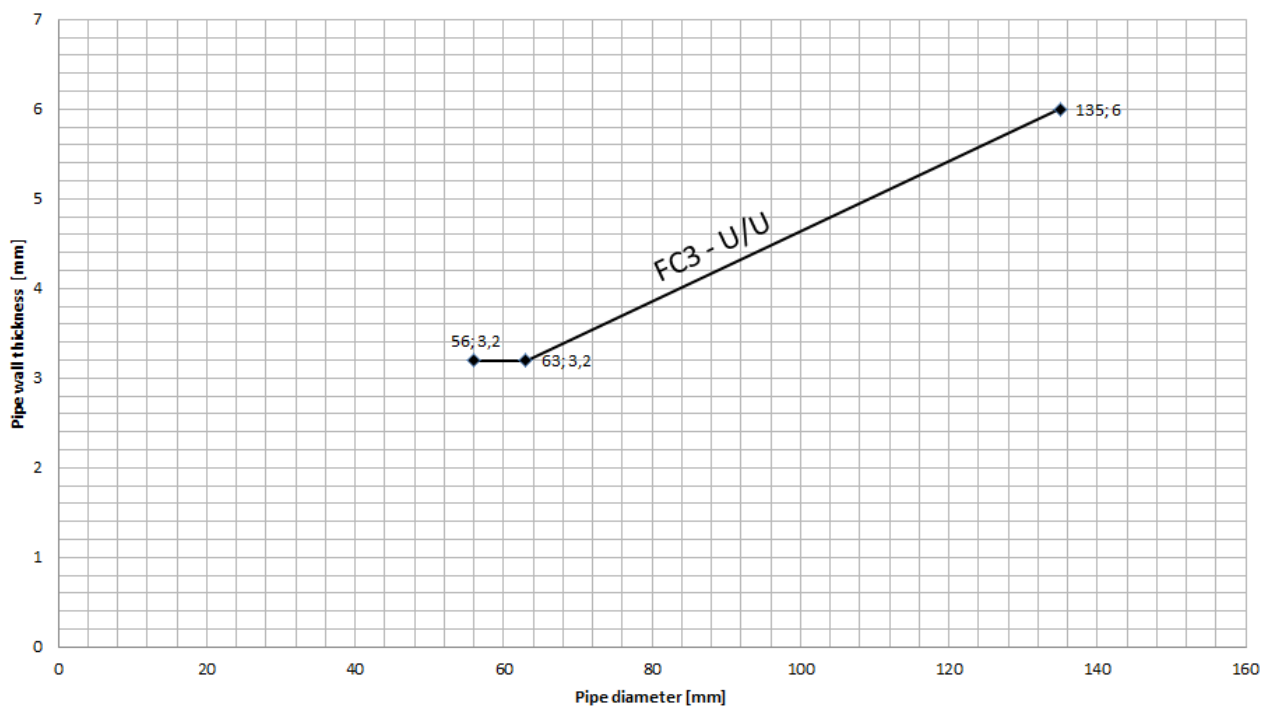

Pipelife Master3	Ø 75 / t <sub>D</sub> 2,1 - Ø 125 / t <sub>D</sub> 3,5	Floor	FC3	1 x 50	EI 60-U/U E 60-U/U
		Floor	FC3	1 x 80	EI 90-U/U E 90-U/U
		Floor	FC3	2 x 50	EI 90-U/U E 90-U/U

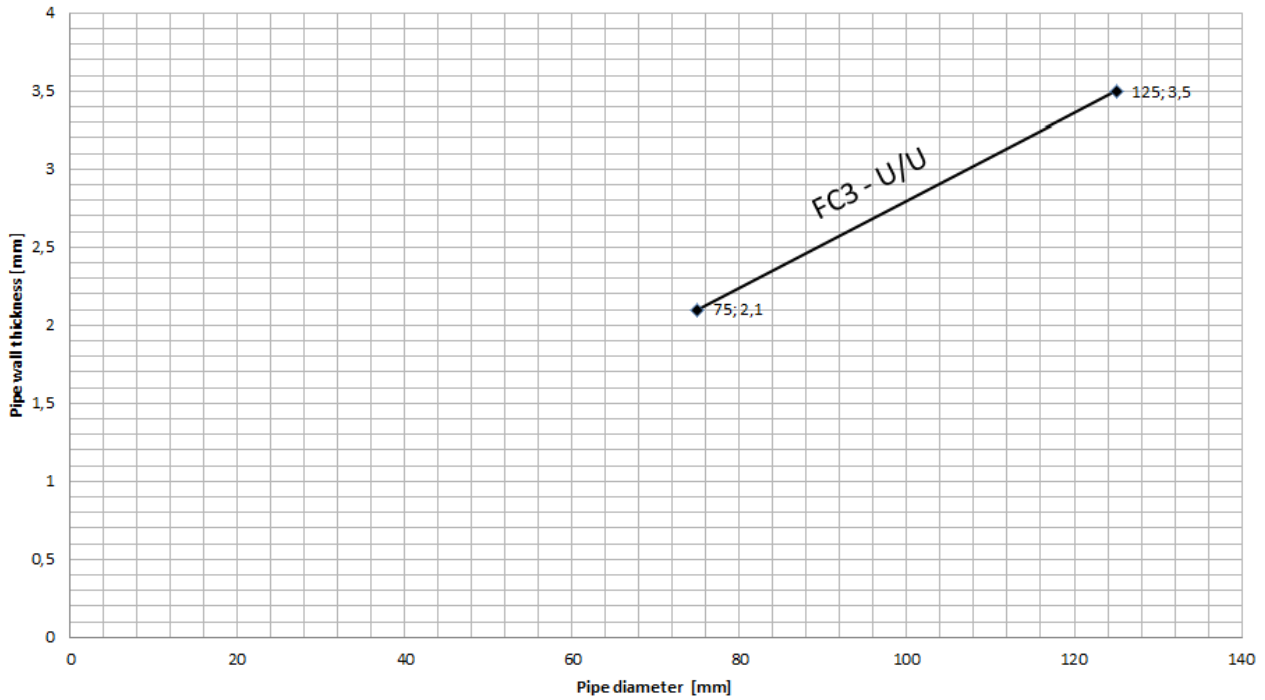

Pipelife Master3	Ø 75 / t <sub>D</sub> 2,1 - Ø 125 / t <sub>D</sub> 3,5	Wall	FC3	1 x 50	EI 60-U/U E 60-U/U
		Wall	FC3	1 x 80	EI 90-U/U E 90-U/U
		Wall	FC3	2 x 50	EI 90-U/U E 90-U/U

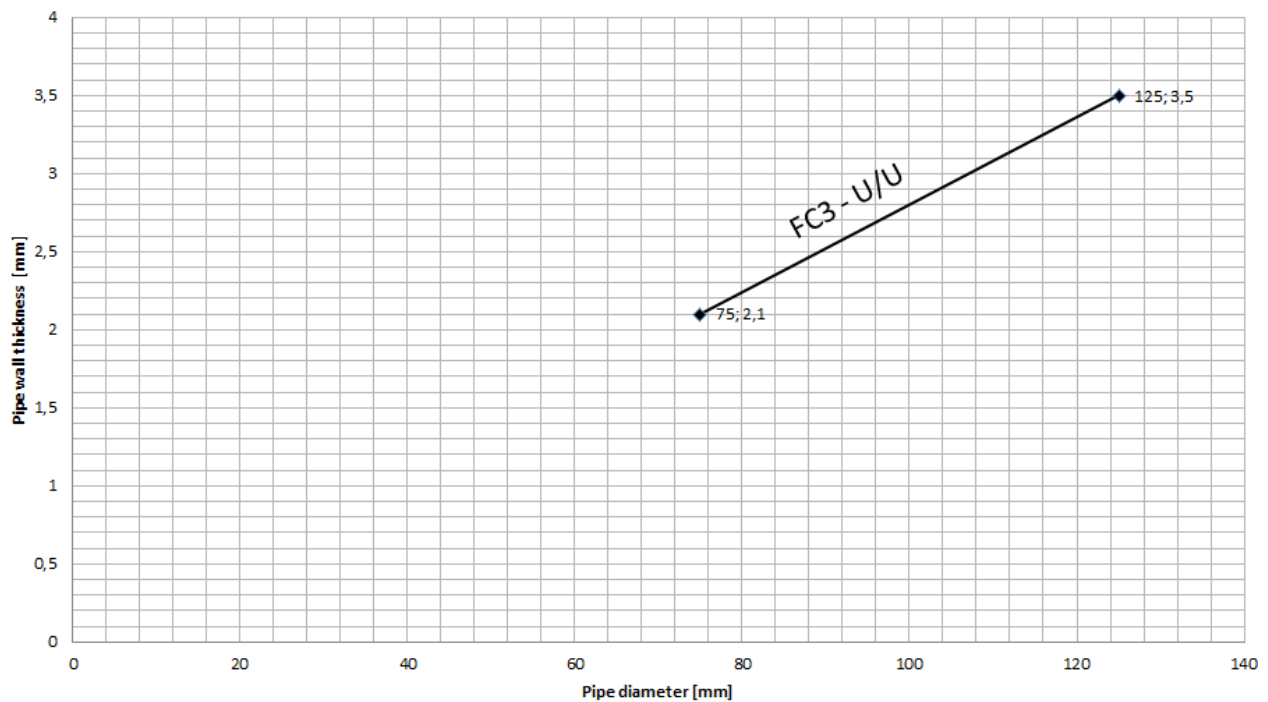

Poloplast PoloKal NG	Ø 32 / t <sub>b</sub> 1,8 - Ø 250 / t <sub>b</sub> 8,6	Floor	FC3/6	1 x 50	EI 60-U/U E 60-U/U
		Floor	FC3/6	1 x 80	EI 90-U/U E 90-U/U
		Floor	FC3/6	2 x 50	EI 90-U/U E 90-U/U

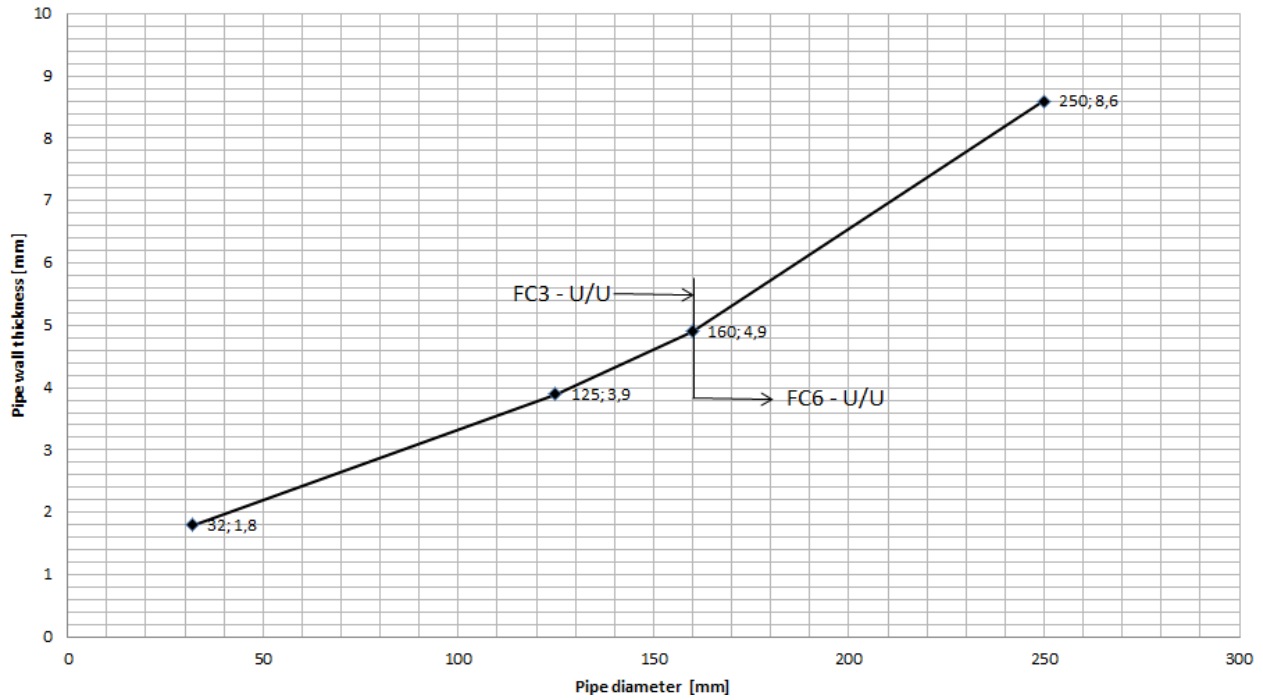

Poloplast PoloKal NG	Ø 32 / t <sub>b</sub> 1,8 - Ø 160 / t <sub>b</sub> 4,9	Wall	FC3	2 x 50	EI 120-U/U E 120-U/U
----------------------	--	------	-----	--------	-------------------------

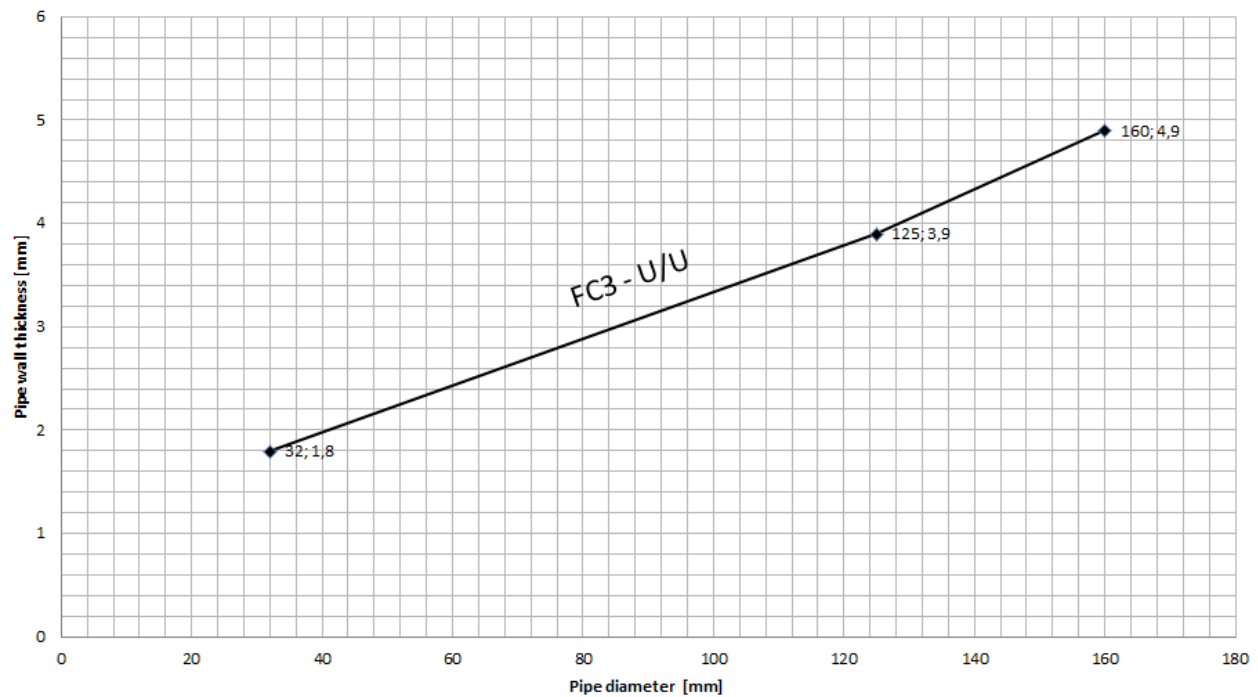

Poloplast PoloKal NG	Ø 32 / t <sub>D</sub> 1,8 - Ø 250 / t <sub>D</sub> 8,6	Wall	FC3/6	1 x 50	EI 60-U/U E 60-U/U
		Wall	FC3/6	1 x 80	EI 90-U/U E 90-U/U
		Wall	FC3/6	2 x 50	EI 90-U/U E 90-U/U

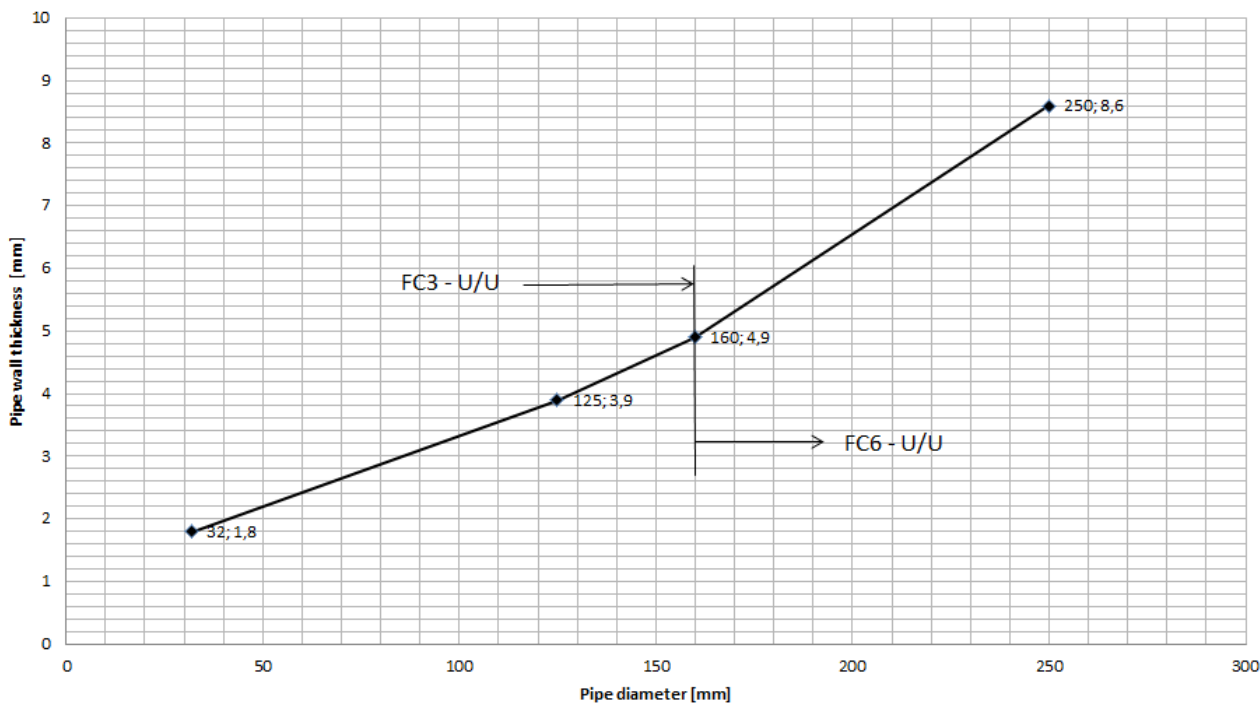

Poloplast PoloKal XS	Ø 32 / t <sub>D</sub> 1,8 - Ø 250 / t <sub>D</sub> 8,6	Floor	FC3/6	1 x 50	EI 60-U/U E 60-U/U
		Floor	FC3/6	1 x 80	EI 90-U/U E 90-U/U
		Floor	FC3/6	2 x 50	EI 90-U/U E 90-U/U

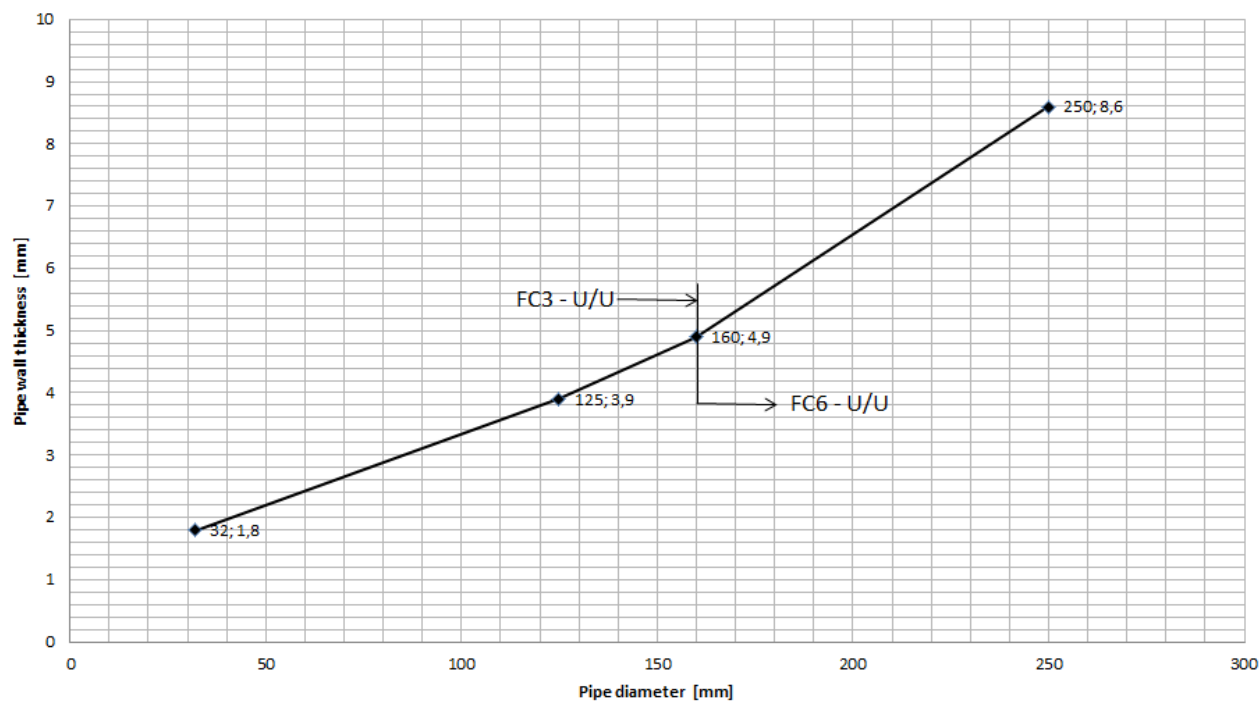



Poloplast PoloKal XS	Ø 32 / t <sub>D</sub> 1,8 - Ø 160 / t <sub>D</sub> 4,9	Wall	FC3	2 x 50	EI 120-U/U E 120-U/U
----------------------	--	------	-----	--------	-------------------------

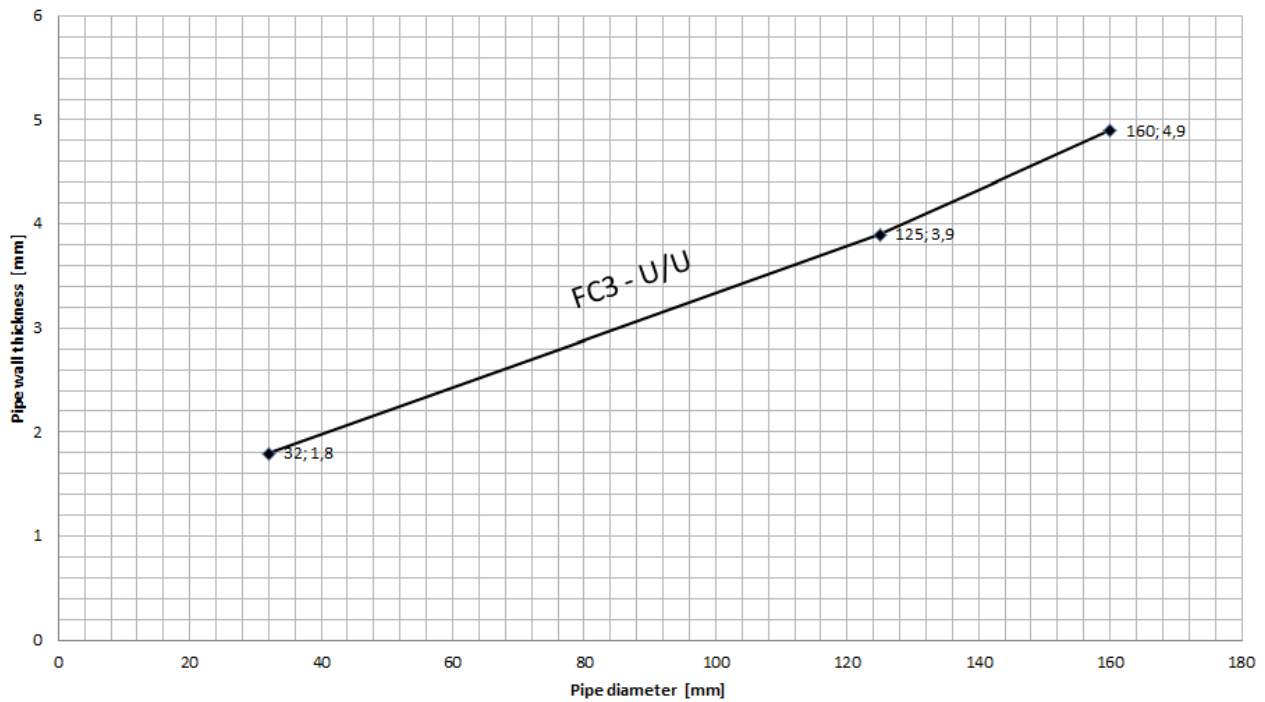

Poloplast PoloKal XS	Ø 32 / t <sub>D</sub> 1,8 - Ø 250 / t <sub>D</sub> 8,6	Wall	FC3/6	1 x 50	EI 60-U/U E 60-U/U
		Wall	FC3/6	1 x 80	EI 90-U/U E 90-U/U
		Wall	FC3/6	2 x 50	EI 90-U/U E 90-U/U

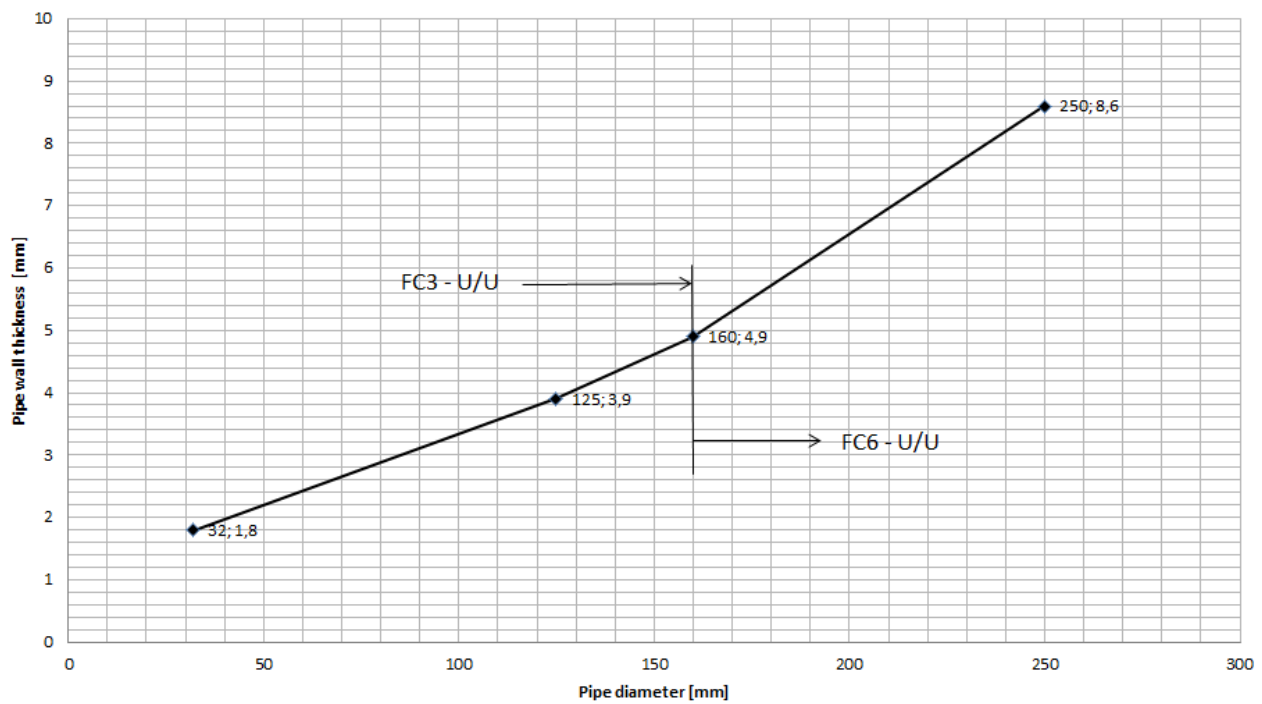

Poloplast PoloKal 3S	Ø 75 / t <sub>D</sub> 3,8 - Ø 160 / t <sub>D</sub> 7,5	Floor	FC3	1 x 50	EI 60-U/U E 60-U/U
		Floor	FC3	1 x 80	EI 90-U/U E 90-U/U
		Floor	FC3	2 x 50	EI 90-U/U E 90-U/U

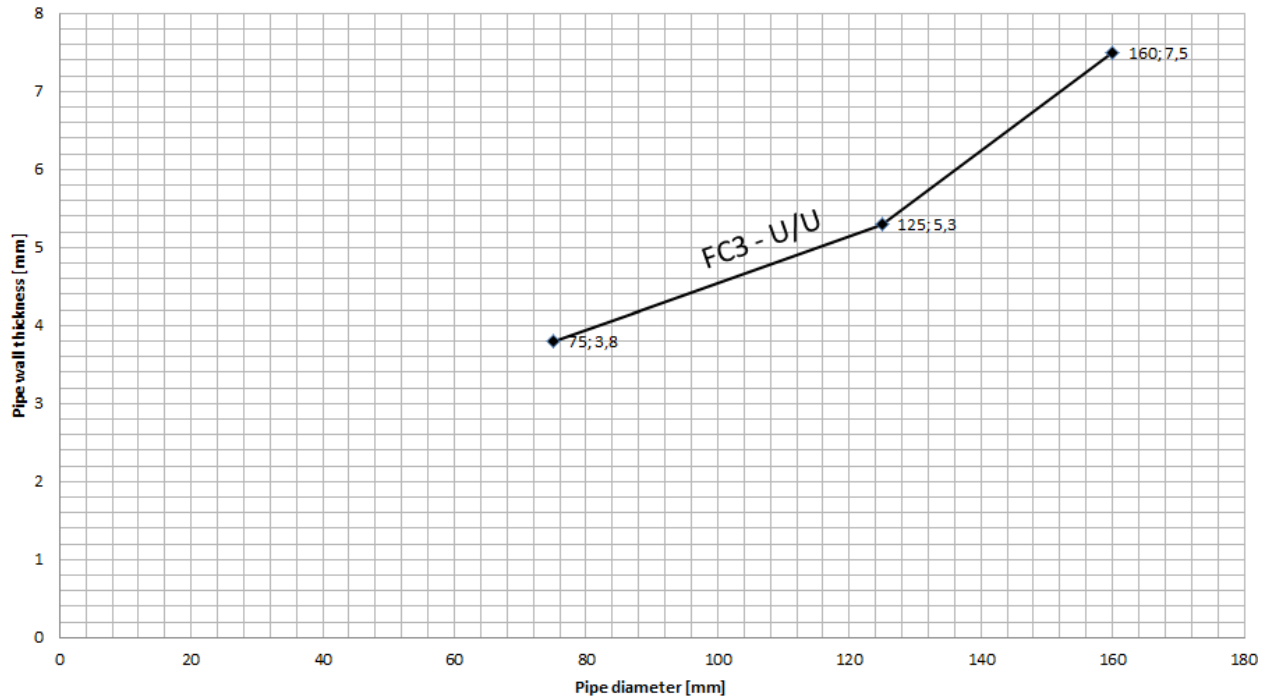

Poloplast PoloKal 3S	Ø 75 / t <sub>D</sub> 3,8 - Ø 160 / t <sub>D</sub> 7,5	Wall	FC3	1 x 50	EI 60-U/U E 60-U/U
		Wall	FC3	1 x 80	EI 90-U/U E 90-U/U
		Wall	FC3	2 x 50	EI 120-U/U E 120-U/U

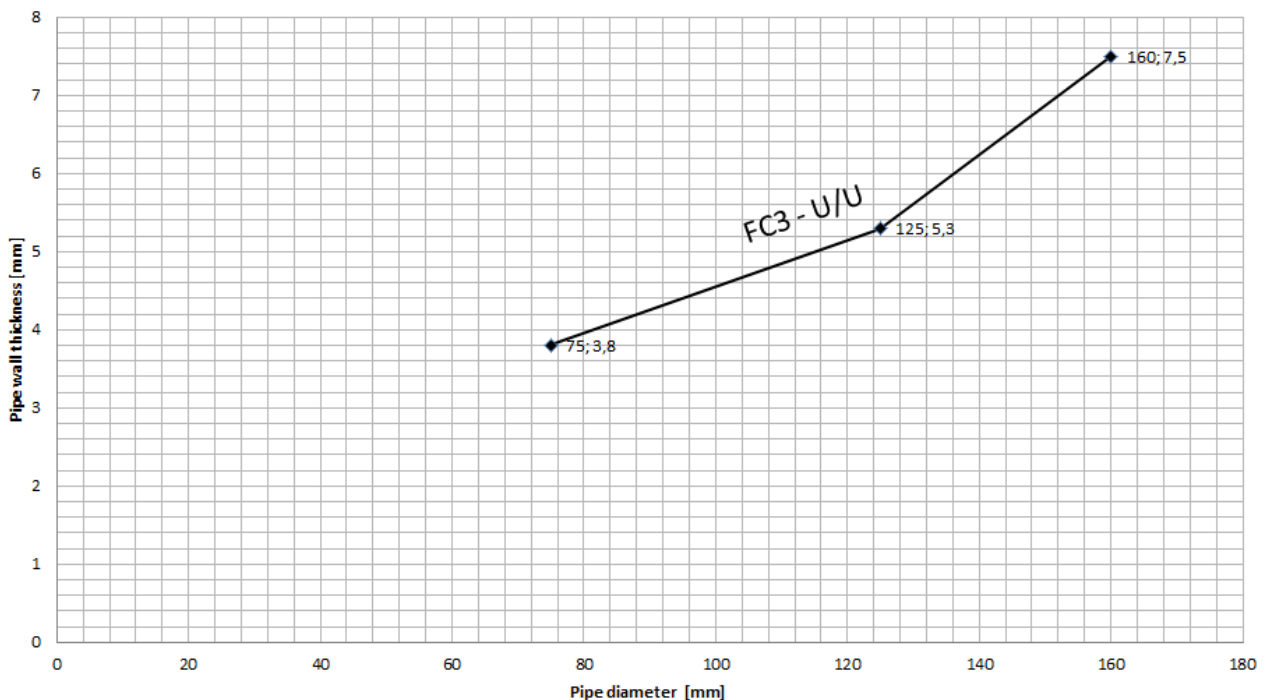

PVC-U	Ø 32 / t <sub>D</sub> 1,8 - Ø 250 / t <sub>D</sub> 4,9	Floor	FC3/6	1 x 50	EI 60-U/U E 60-U/U
		Floor	FC3/6	1 x 80	EI 90-U/U E 90-U/U
		Floor	FC3/6	2 x 50	EI 90-U/U E 90-U/U

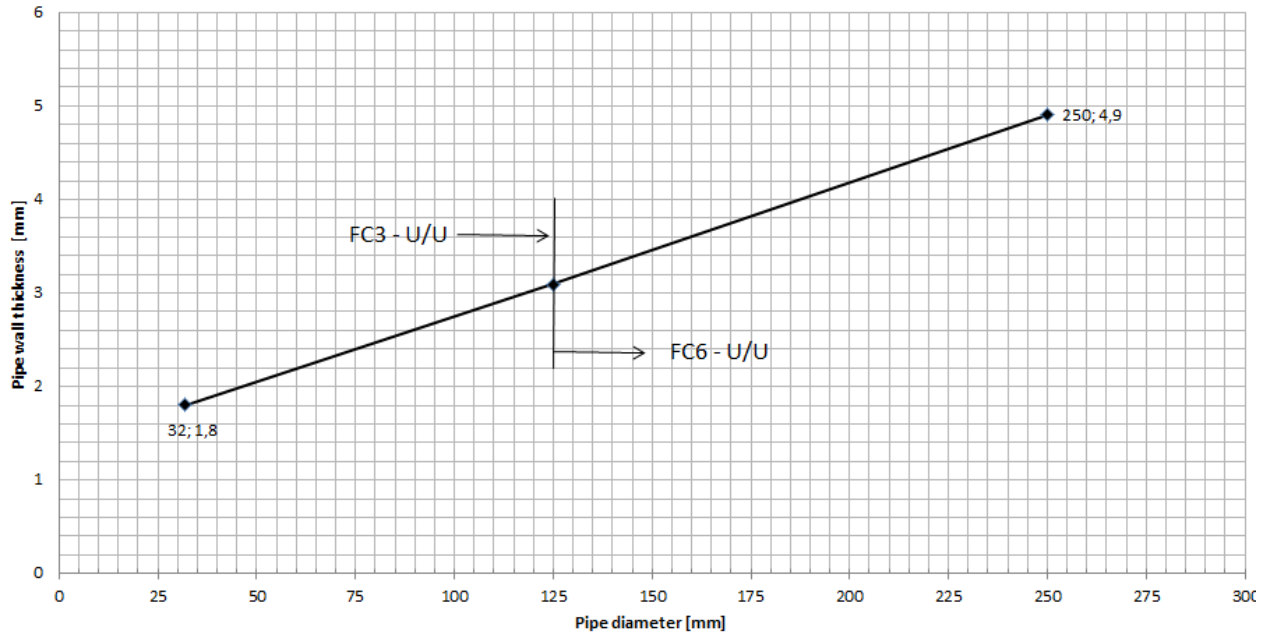

PVC-U	Ø 125 / t <sub>D</sub> 3,2 - Ø 160 / t <sub>D</sub> 3,6	Floor (built in)	FC3/6	2 x 50	EI 90-U/U E 90-U/U
-------	---	---------------------	-------	--------	-----------------------

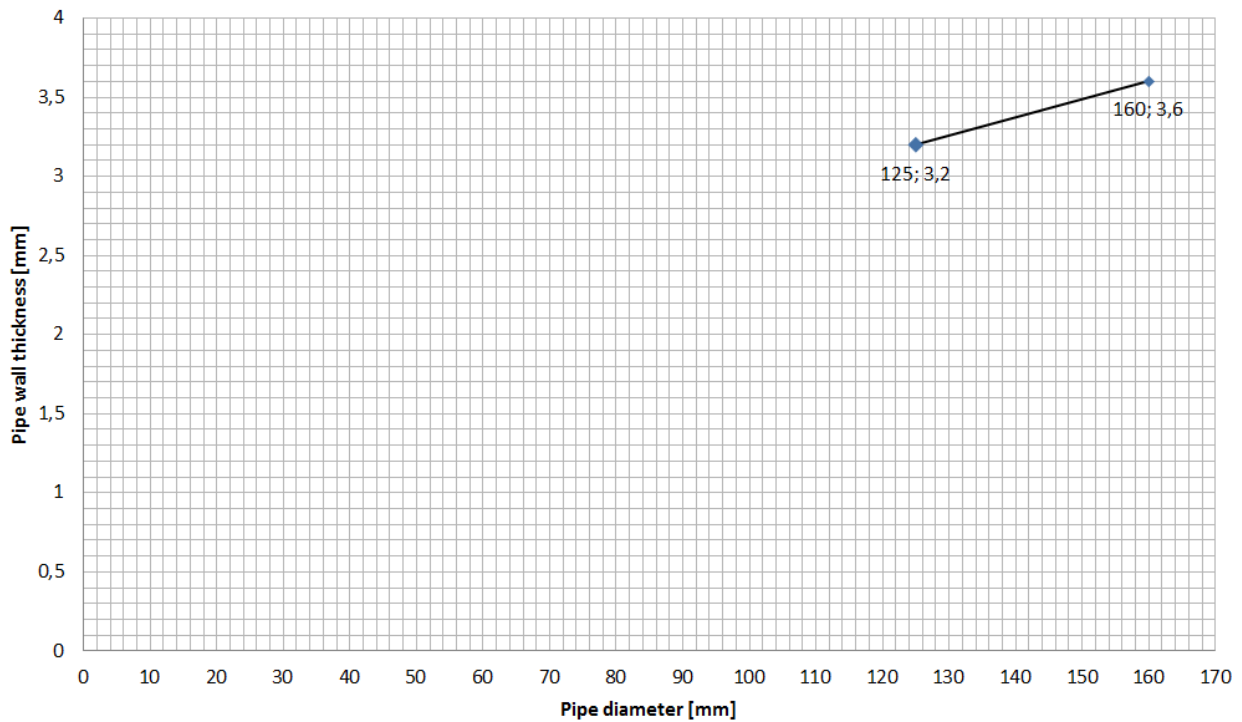

PE-HD	Ø 32 / t <sub>b</sub> 1,8 - Ø 200 / t <sub>b</sub> 11,4	Floor	FC3/6	1 x 50	EI 60-U/U E 60-U/U
		Floor	FC3/6	1 x 80	EI 90-U/U E 90-U/U
		Floor	FC3/6	2 x 50	EI 90-U/U E 90-U/U

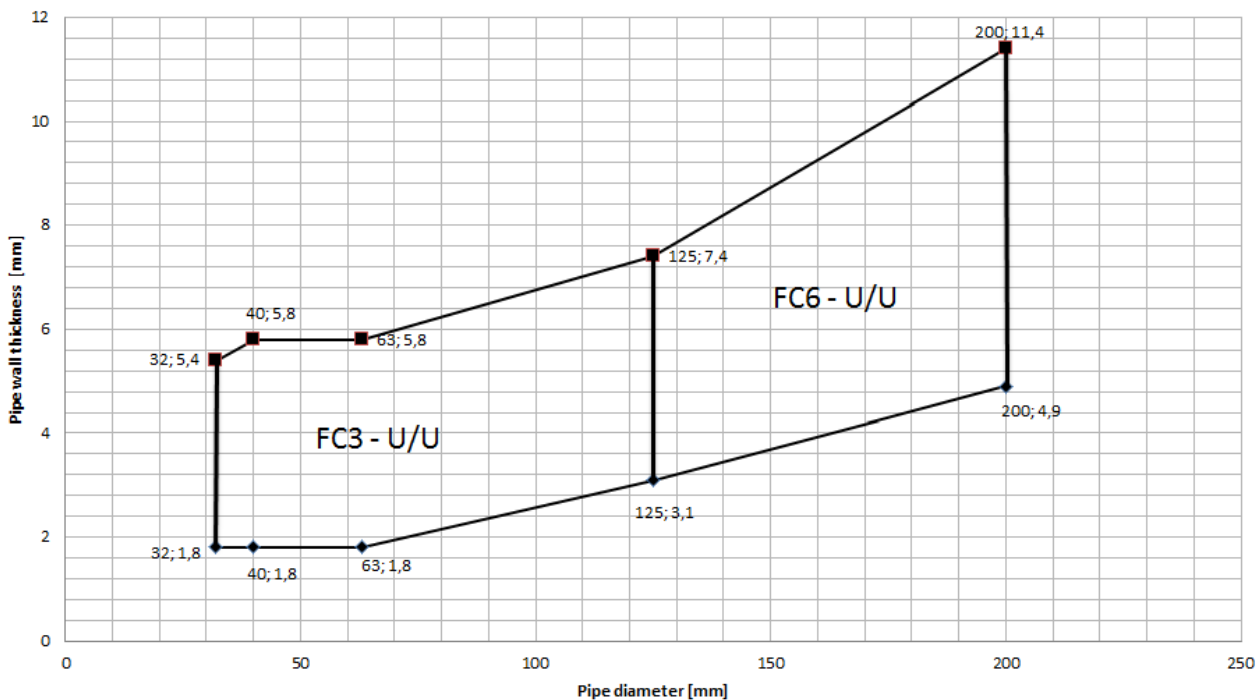

PE-HD	Ø 40 / t <sub>b</sub> 1,8 - Ø 200 / t <sub>b</sub> 11,4	Wall	FC3/6	1 x 50	EI 60-U/U
		Wall	FC3/6	1 x 80	EI 90-U/U
		Wall	FC3/6	2 x 50	EI 90-U/U

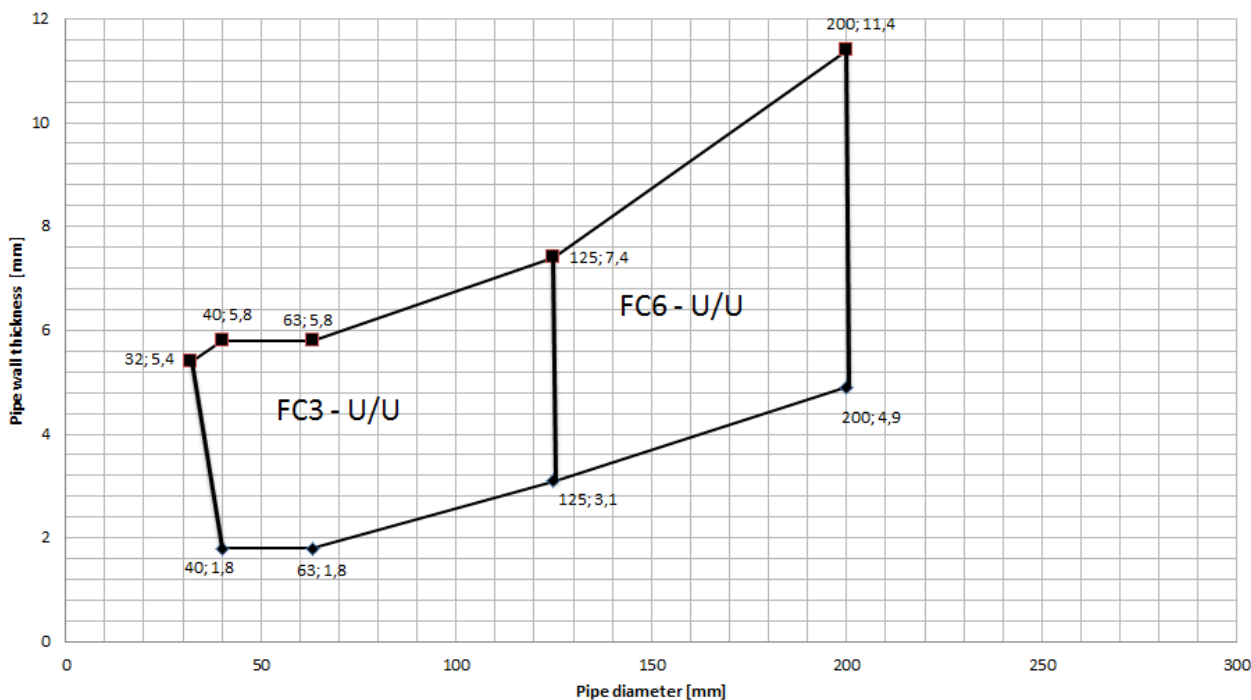

PE-HD	Ø 40 / t <sub>D</sub> 1,8 - Ø 200 / t <sub>D</sub> 11,4	Wall (built in)	FC3/6	2 x 50	EI 90-U/U E 90-U/U
-------	---	--------------------	-------	--------	-----------------------

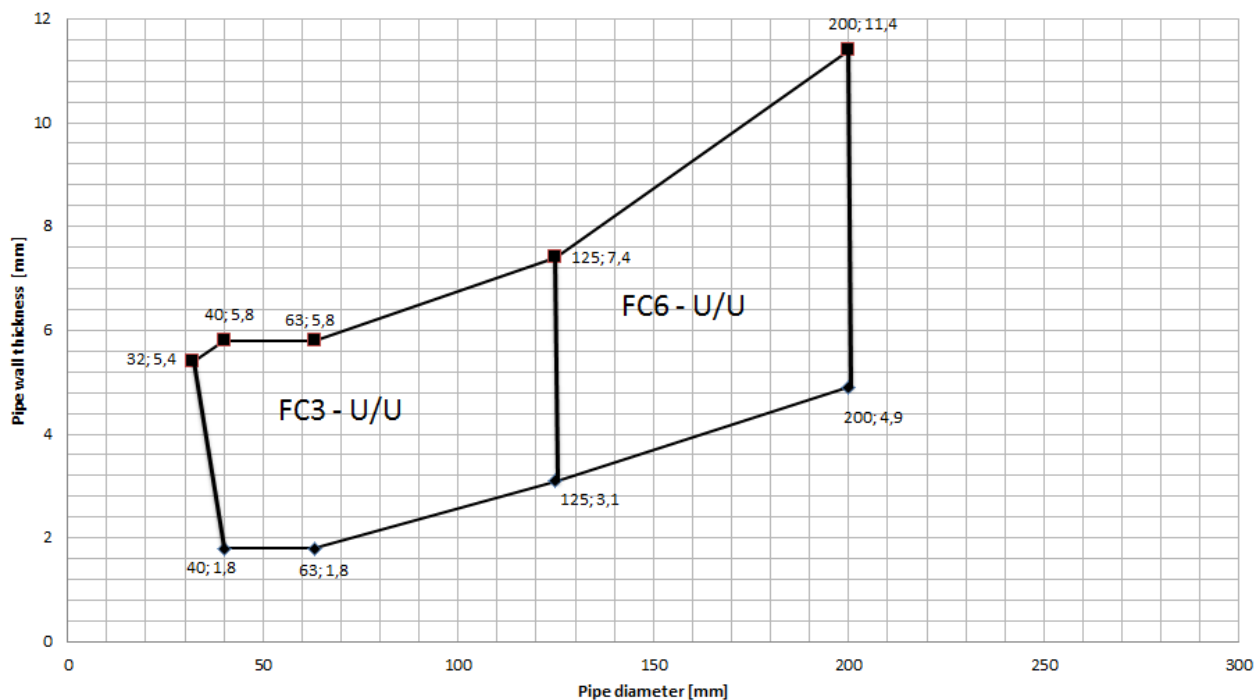

PP-H / PP-R	Ø 32 / t <sub>D</sub> 1,8 - Ø 200 / t <sub>D</sub> 11,4	Floor	FC3/6	1 x 50	EI 60-U/U E 60-U/U
		Floor	FC3/6	1 x 80	EI 90-U/U E 90-U/U
		Floor	FC3/6	2 x 50	EI 90-U/U E 90-U/U

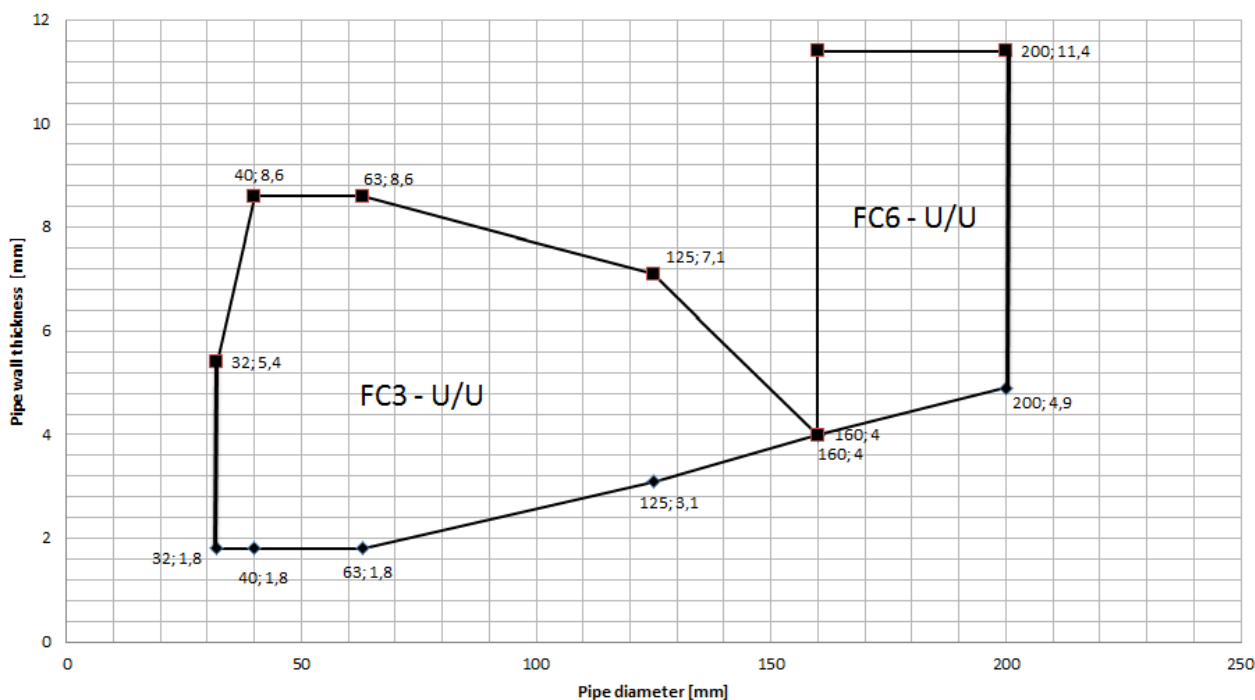

PP-H / PP-R	Ø 40 / t <sub>D</sub> 1,8 - Ø 250 / t <sub>D</sub> 14,2	Wall	FC3/6	1 x 50	EI 60-U/U E 60-U/U
		Wall	FC3/6	1 x 80	EI 90-U/U E 90-U/U
		Wall	FC3/6	2 x 50	EI 90-U/U E 90-U/U

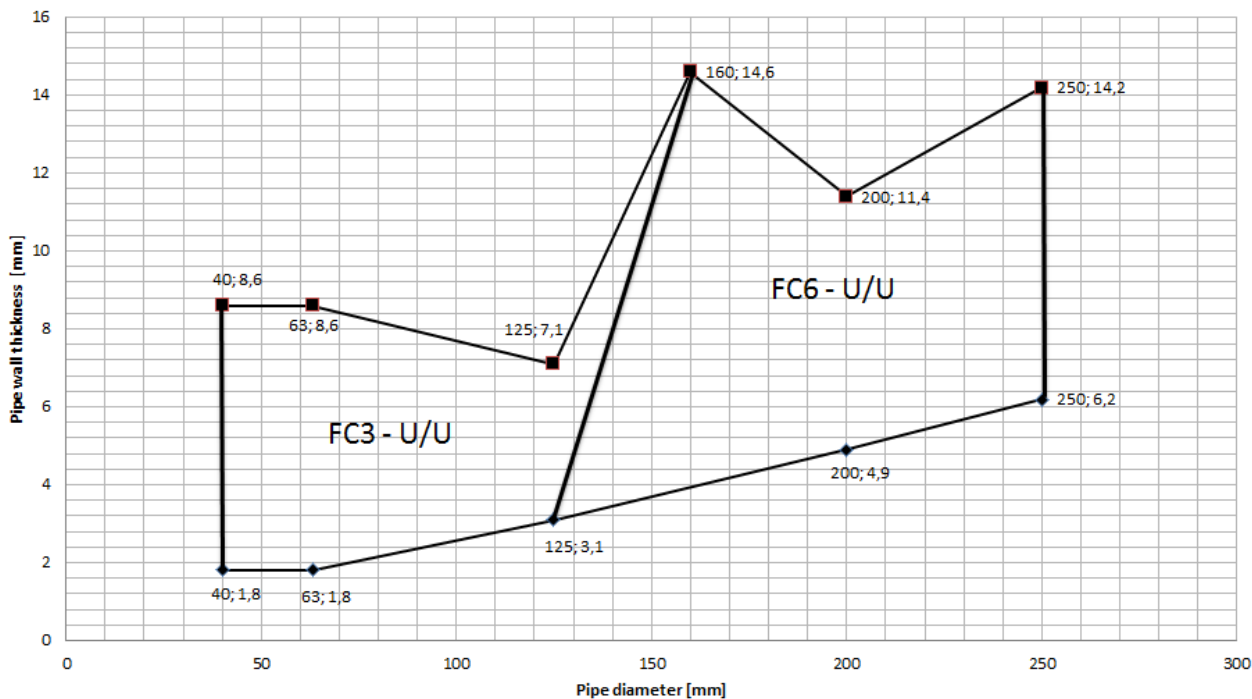

PP-H / PP-R	Ø 75 / t <sub>D</sub> 2,6 - Ø 90 / t <sub>D</sub> 3,0	Floor (built in)	FC3/6	2 x 50	EI 90-U/U E 90-U/U
-------------	---	---------------------	-------	--------	-----------------------

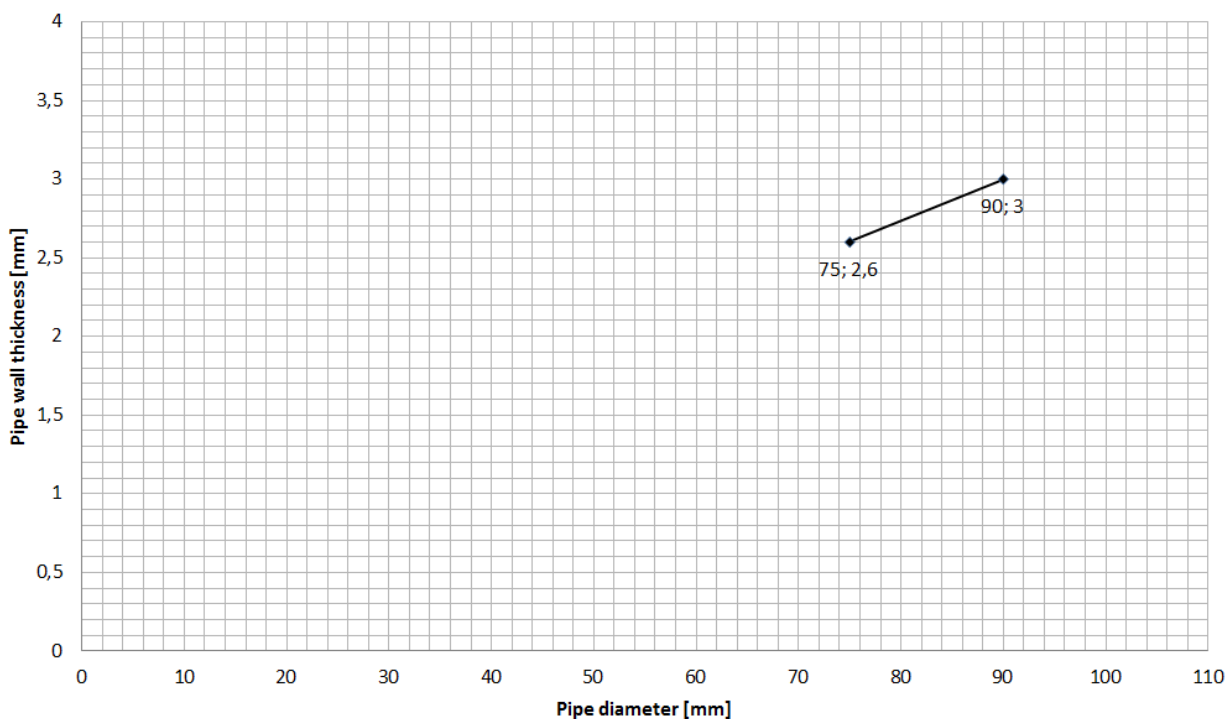

PP-H / PP-R	Ø 40 / t <sub>D</sub> 1,8 - Ø 250 / t <sub>D</sub> 14,2	Wall	FC6	2 x 50	EI 120-U/U E 120-U/U
-------------	---	------	-----	--------	-------------------------

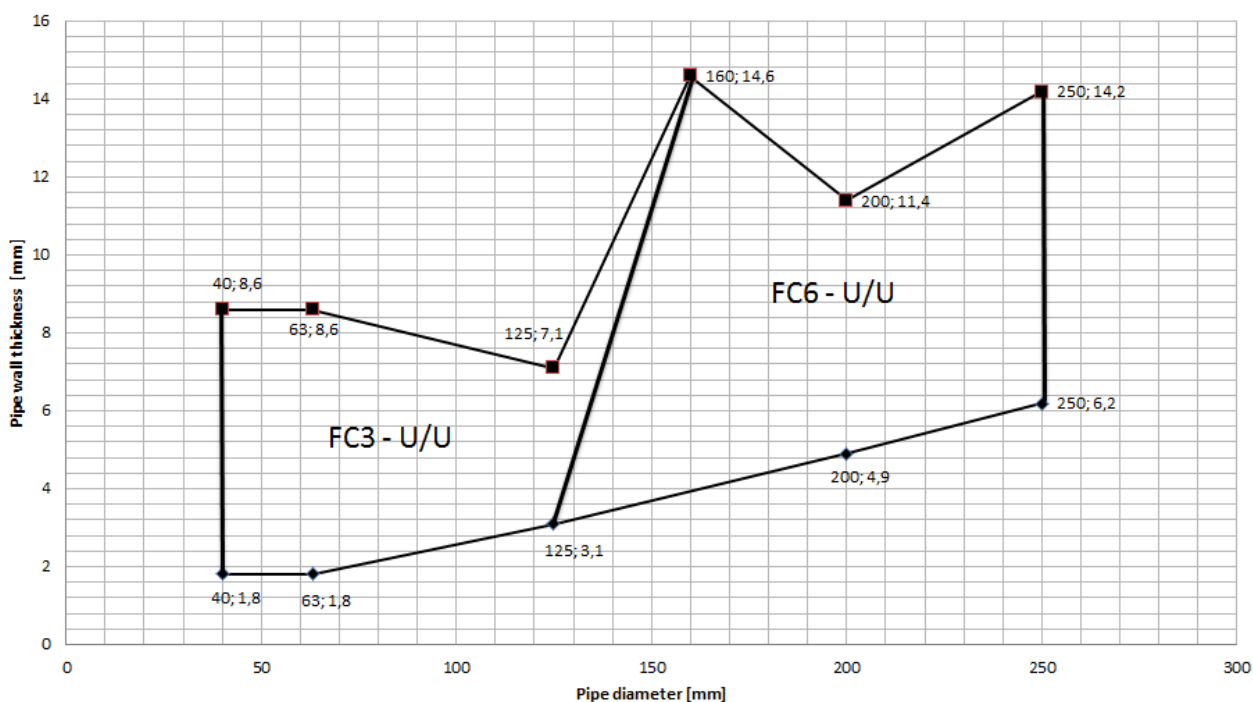

Rehau Raupiano Plus	Ø 40 / t <sub>D</sub> 1,8 - Ø 200 / t <sub>D</sub> 6,2	Floor	FC6	1 x 50	EI 60-U/U E 60-U/U
		Floor	FC6	1 x 80	EI 90-U/U E 90-U/U
		Floor	FC6	2 x 50	EI 90-U/U E 90-U/U

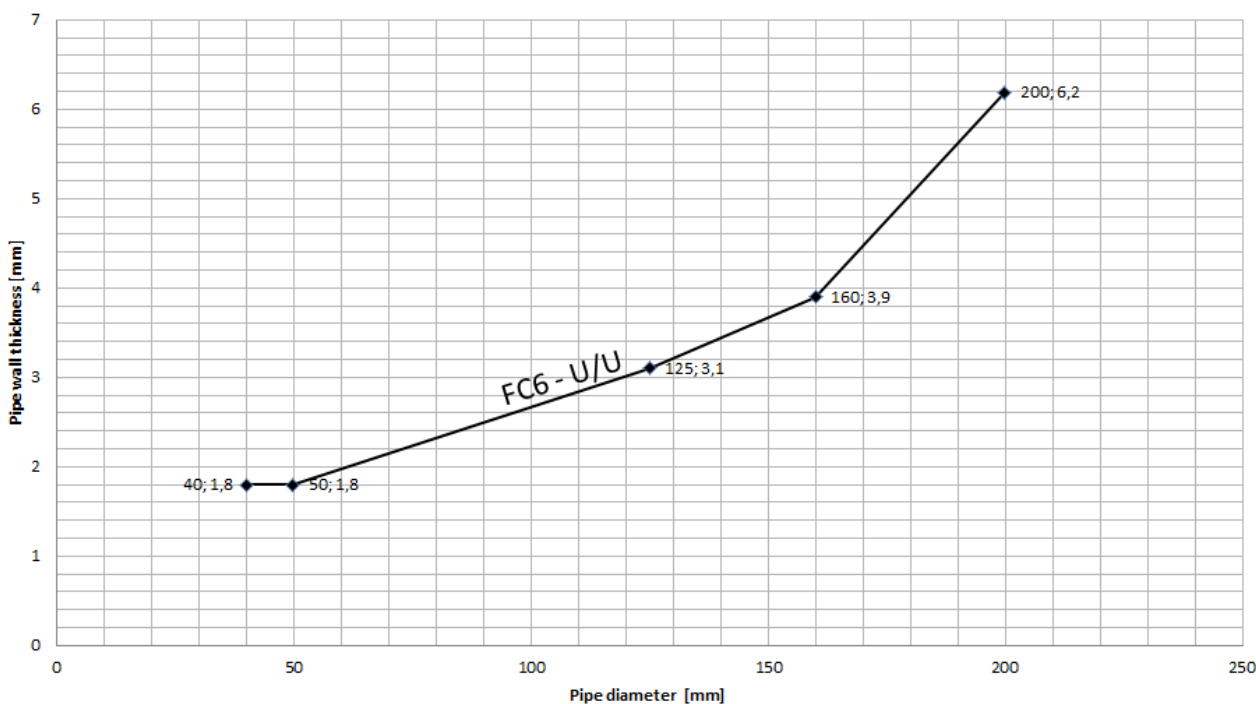

Rehau Raupiano Plus (+coupling)	Ø 40 / t <sub>b</sub> 1,8 - Ø 125 / t <sub>b</sub> 3,1	Floor	FC6	1 x 50	EI 60-U/U E 60-U/U
		Floor	FC6	1 x 80	EI 90-U/U E 90-U/U
		Floor	FC6	2 x 50	EI 90-U/U E 90-U/U

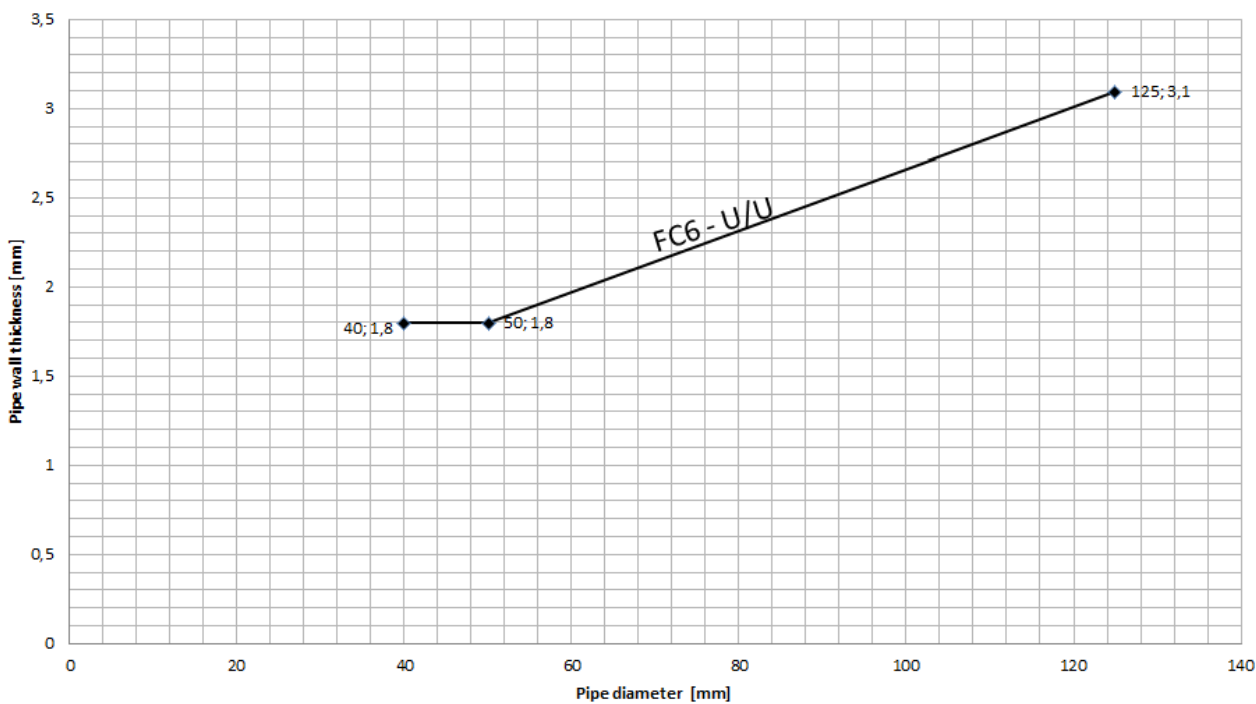

Rehau Raupiano Plus (+coupling)	Ø 40 / t <sub>b</sub> 1,8 - Ø 125 / t <sub>b</sub> 3,1	Wall	FC6	1 x 50	EI 60-U/U E 60-U/U
		Wall	FC6	1 x 80	EI 90-U/U E 90-U/U
		Wall	FC6	2 x 50	EI 120-U/U E 120-U/U

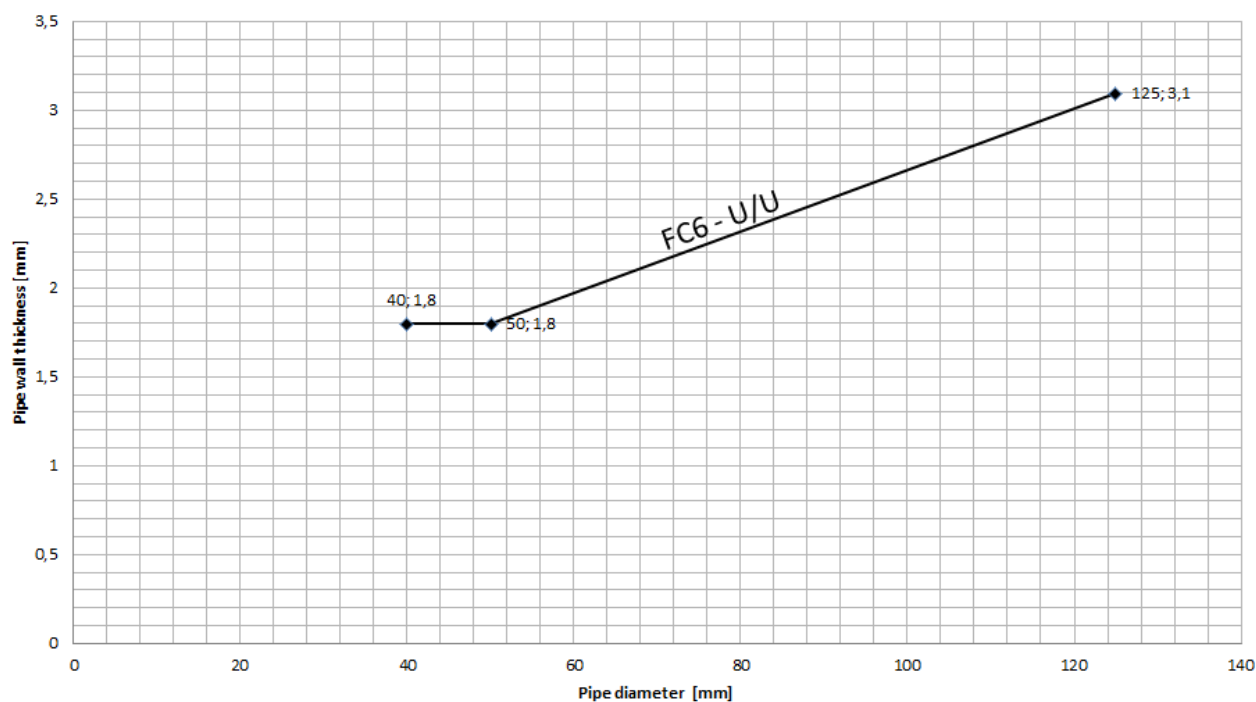



### 3.15 Distances

#### **Supporting distances:**

The installations must be suspended  $\leq 250$  mm on both sides from walls or on top of floor constructions.

#### **Distances in or between products:**

Specimen	Minimum distance (mm)
Non-combustible insulation – non-combustible insulation	0
Non-combustible insulation – Reveal / Aperture opening	0
Non-combustible insulation – PROMATECT® duct	0
Non-combustible insulation – PROMASTOP®-FC	0
Cable, cable trays – supporting construction/aperture opening	0
Cable, cable trays – cable, cable trays	0
Cable, cable trays – PROMASTOP®-FC	0
PROMASTOP®-FC – PROMASTOP®-FC	0
PROMASTOP®-FC – PROMATECT® duct	0
PROMASTOP®-FC – supporting construction/aperture opening	0
PROMASTOP®-W – supporting construction/aperture opening	0
PROMASTOP®-W – non-combustible insulation	0
PROMASTOP®-W – PROMASTOP®-W	0
PROMASTOP®-W – PROMASTOP®-FC	25
PROMASTOP®-W – PROMATECT® duct	30

### ANNEX 4 INSTALLATION DRAWINGS

<p>704.01</p>	<p>704.02</p>	<p>704.03</p>	
<p>704.04</p>	<p>704.05</p>	<p>704.06</p>	
<p>704.07</p>	<p>704.08</p>	<p>703.01</p>	
<p>703.05</p>	<p>703.02</p>	<p>703.06</p>	
<p><b>Promat</b> PROMAT GmbH St.-Peter-Strasse 25 4021 Linz / Austria Phone: +43 732 6912 - 3621 Fax: +43 732 6912 - 3740 www.promat.at technik@promat.at</p>	<p>Overview of PROMASTOP®-CC penetration seal constructions part 1 of 3</p>		<p>modified by/on: drawn by: <b>KÖRBLER</b> drawing number: 704.001</p>
<p>scale: without</p>	<p>drawing format: A4</p>	<p>date: 27.05.2016</p>	<p>division: Technik</p>





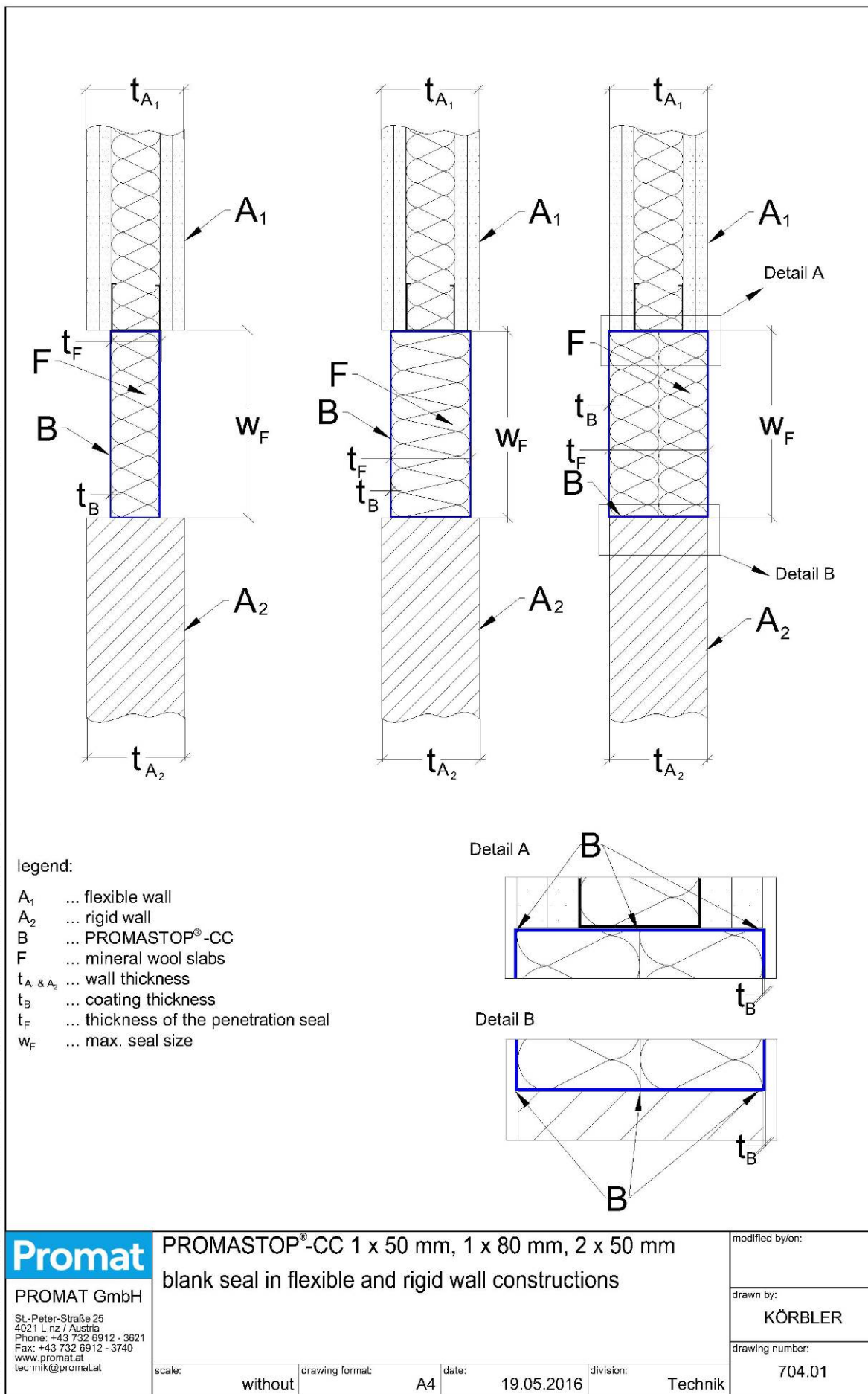

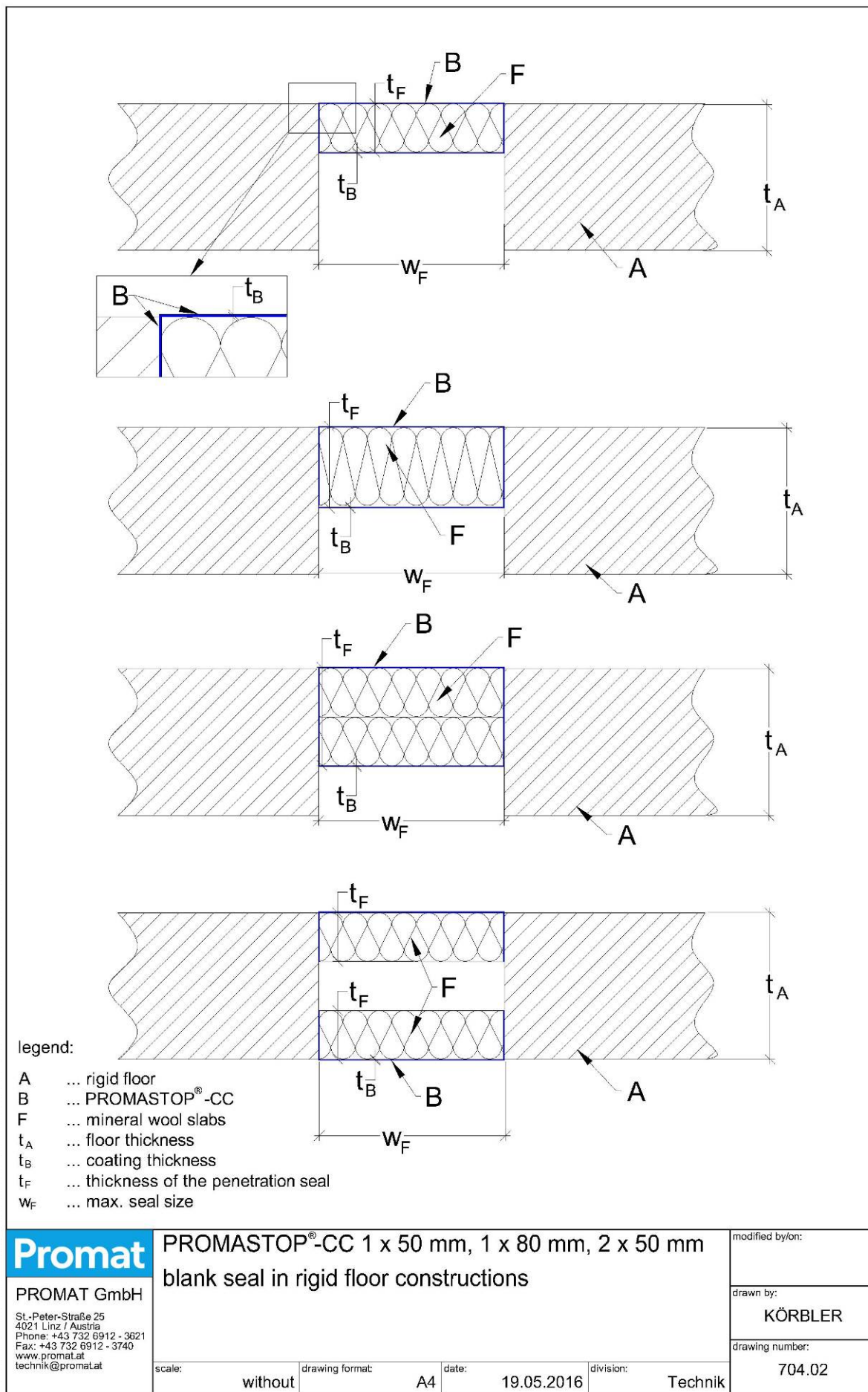

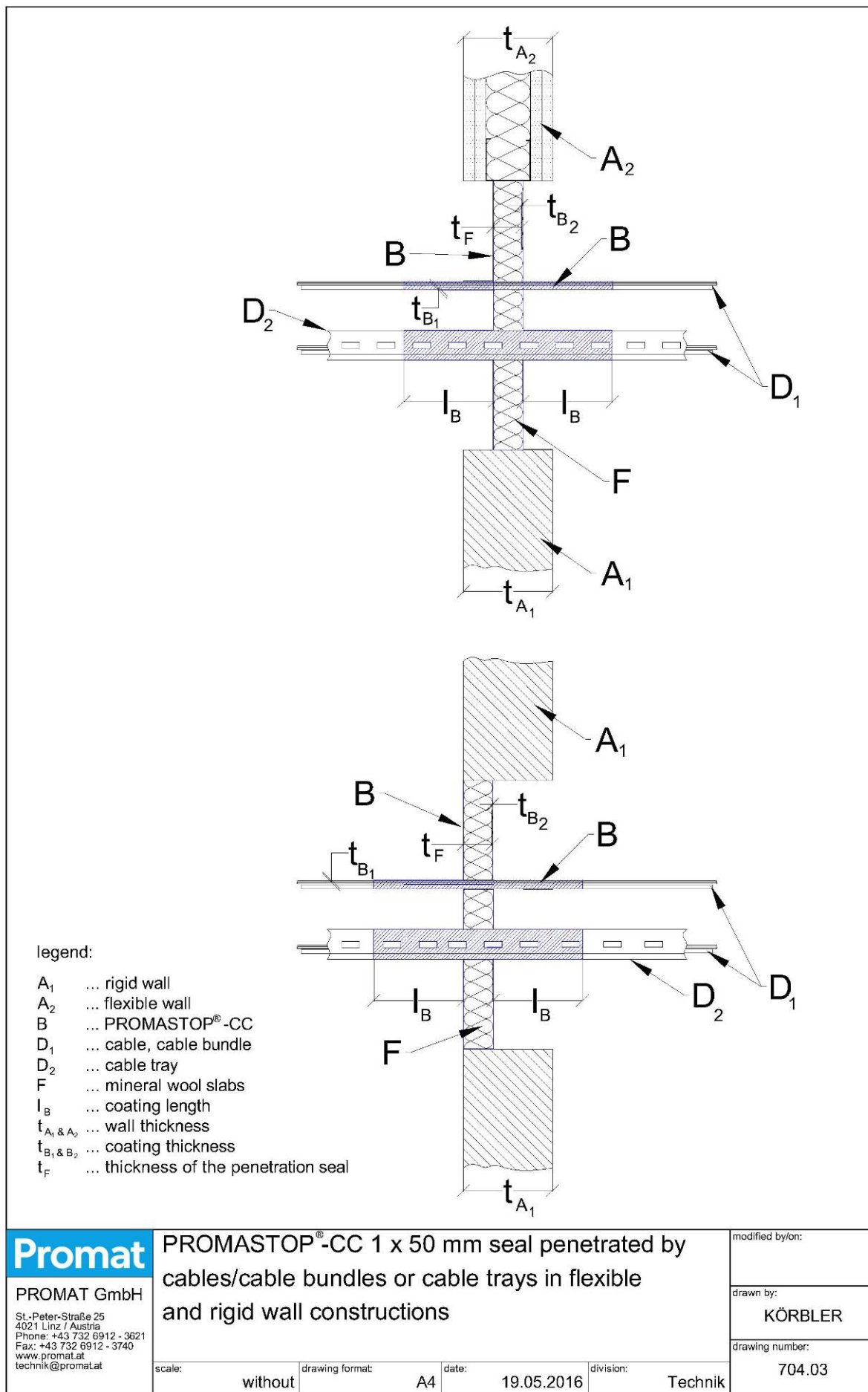

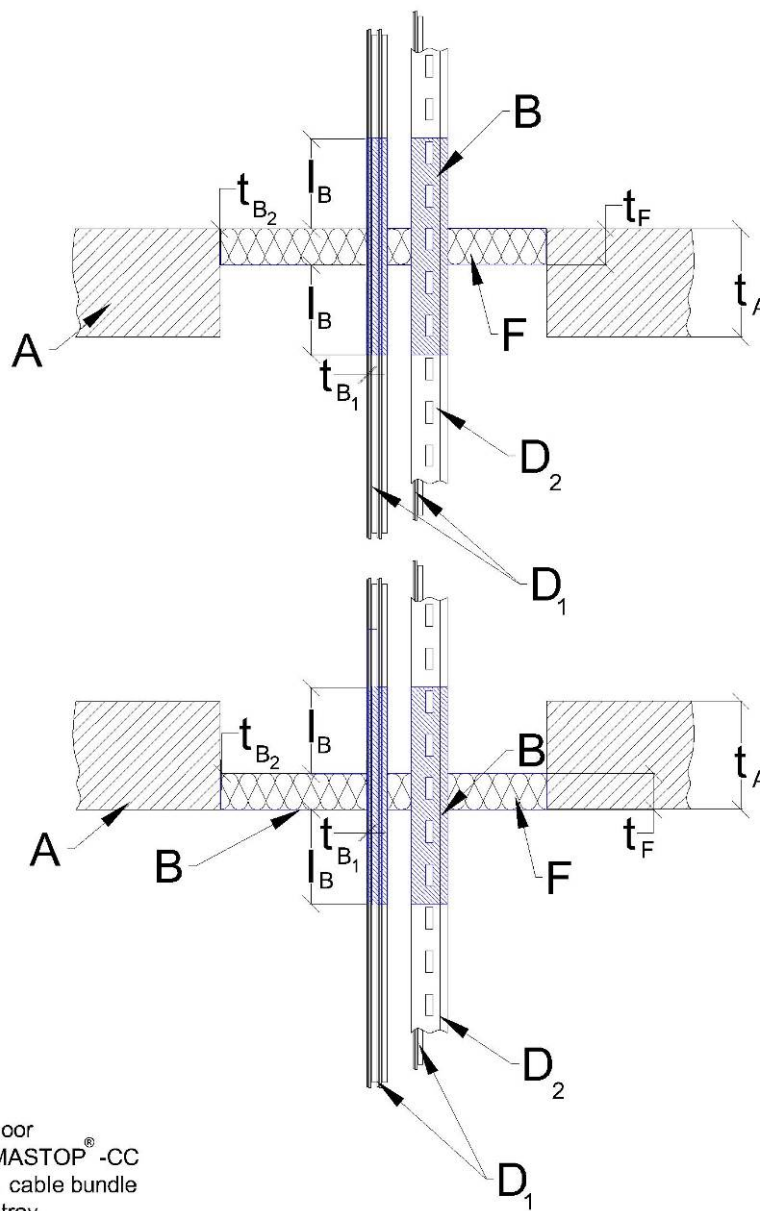

legend:

- A ... rigid floor
- B ... PROMASTOP®-CC
- D<sub>1</sub> ... cable, cable bundle
- D<sub>2</sub> ... cable tray
- F ... mineral wool slabs
- l<sub>B</sub> ... coating length
- t<sub>A</sub> ... floor thickness
- t<sub>B1</sub>, t<sub>B2</sub> ... coating thickness
- t<sub>F</sub> ... thickness of the penetration seal

**Promat**

PROMAT GmbH

St.-Peter-Straße 25  
4021 Linz / Austria  
Phone: +43 732 6912 - 3621  
Fax: +43 732 6912 - 3740  
www.promat.at  
technik@promat.at

PROMASTOP®-CC 1 x 50 mm seal penetrated by  
cables/cable bundles or cable trays in rigid  
floor constructions

scale: without drawing format: A4 date: 19.05.2016 division: Technik

modified by/on:

drawn by:

KÖRBLER

drawing number:

704.04



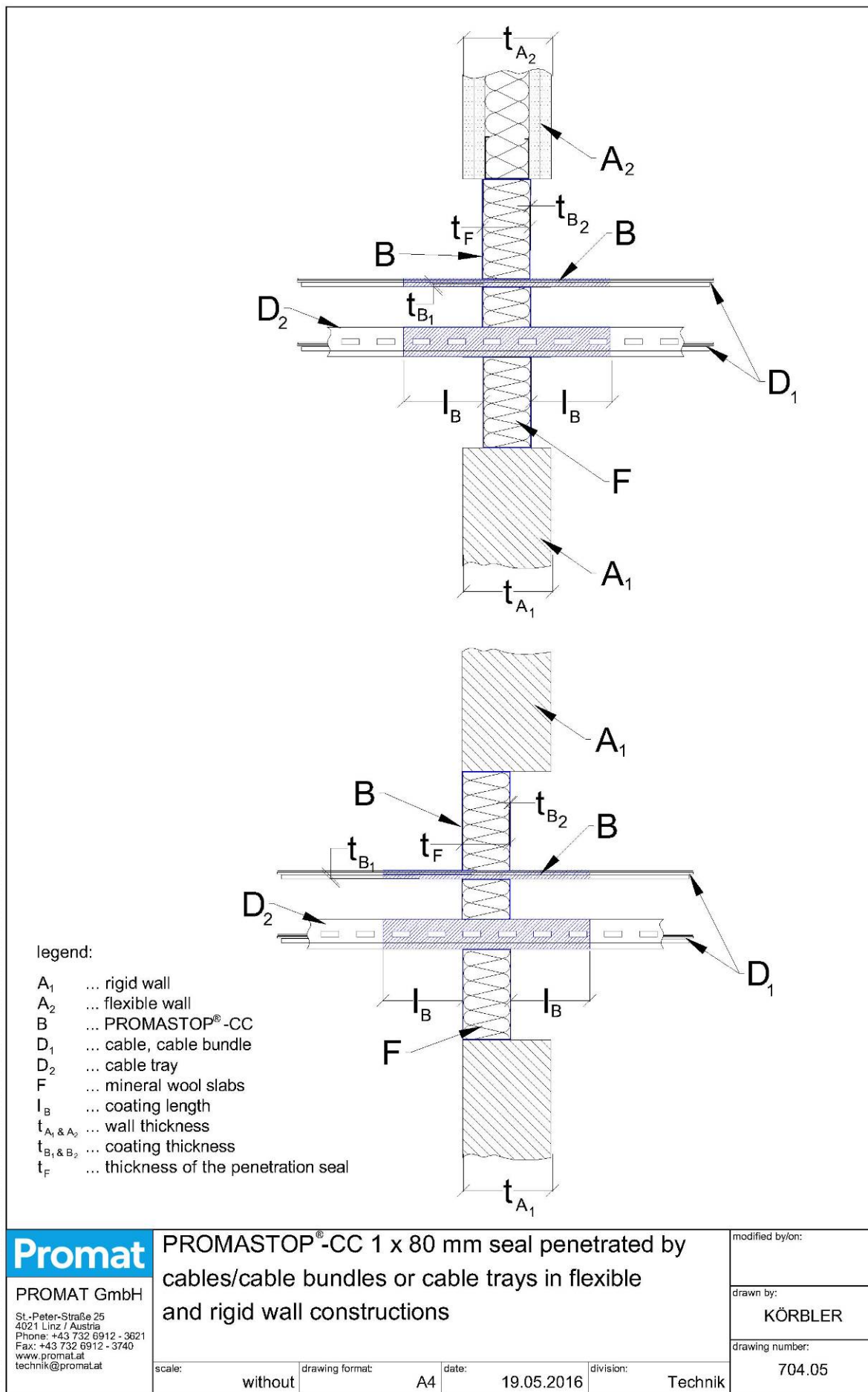

electronic copy electronic copy electronic copy electronic copy electronic copy electronic copy electronic copy electronic copy electronic copy electronic copy

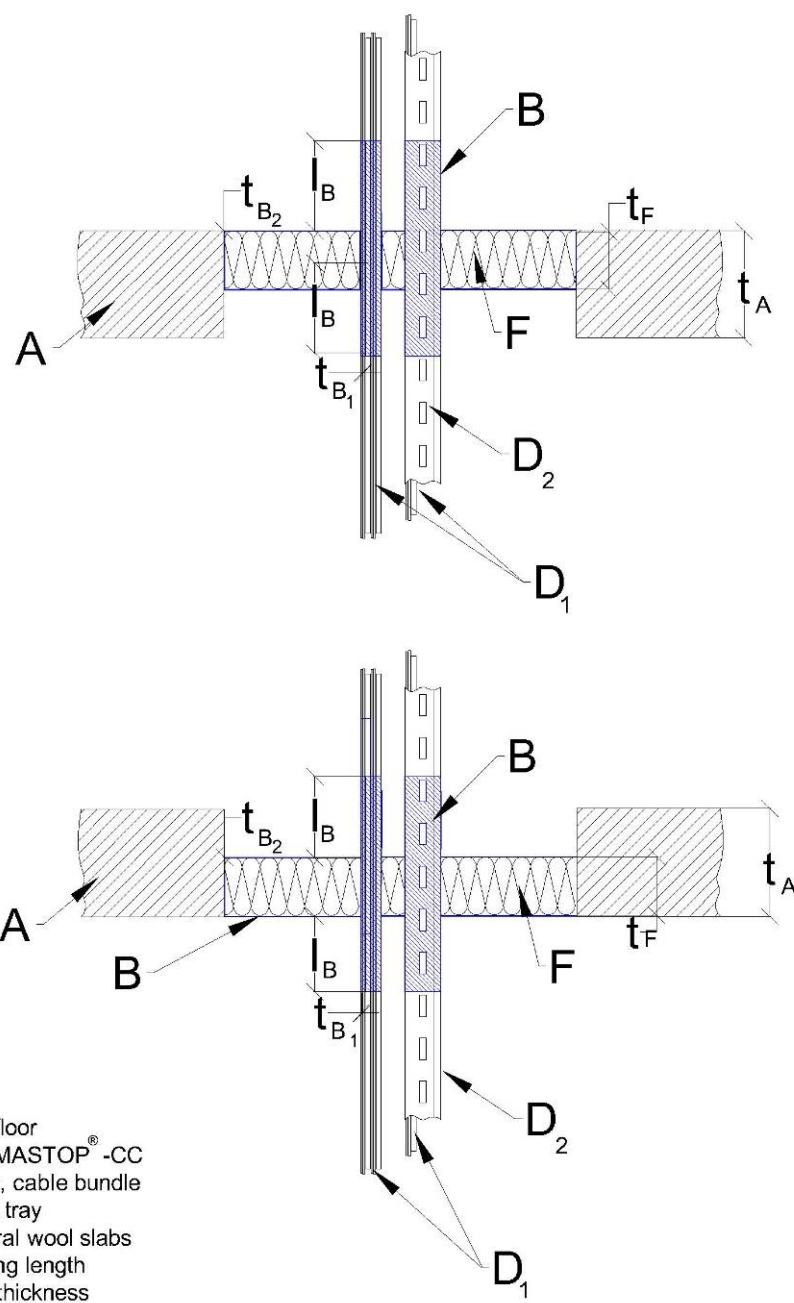

- legend:
- A ... rigid floor
  - B ... PROMASTOP®-CC
  - D<sub>1</sub> ... cable, cable bundle
  - D<sub>2</sub> ... cable tray
  - F ... mineral wool slabs
  - l<sub>B</sub> ... coating length
  - t<sub>A</sub> ... floor thickness
  - t<sub>B1</sub>, t<sub>B2</sub> ... coating thickness
  - t<sub>F</sub> ... thickness of the penetration seal

<b>Promat</b> PROMAT GmbH St.-Peter-Straße 25 4021 Linz / Austria Phone: +43 732 6912 - 3621 Fax: +43 732 6912 - 3740 www.promat.at technik@promat.at	PROMASTOP®-CC 1 x 80 mm seal penetrated by cables/cable bundles or cable trays in rigid floor constructions			modified by/on:
				drawn by: <b>KÖRBLER</b>
				drawing number: <b>704.06</b>
scale: without	drawing format: A4	date: 19.05.2016	division: Technik	

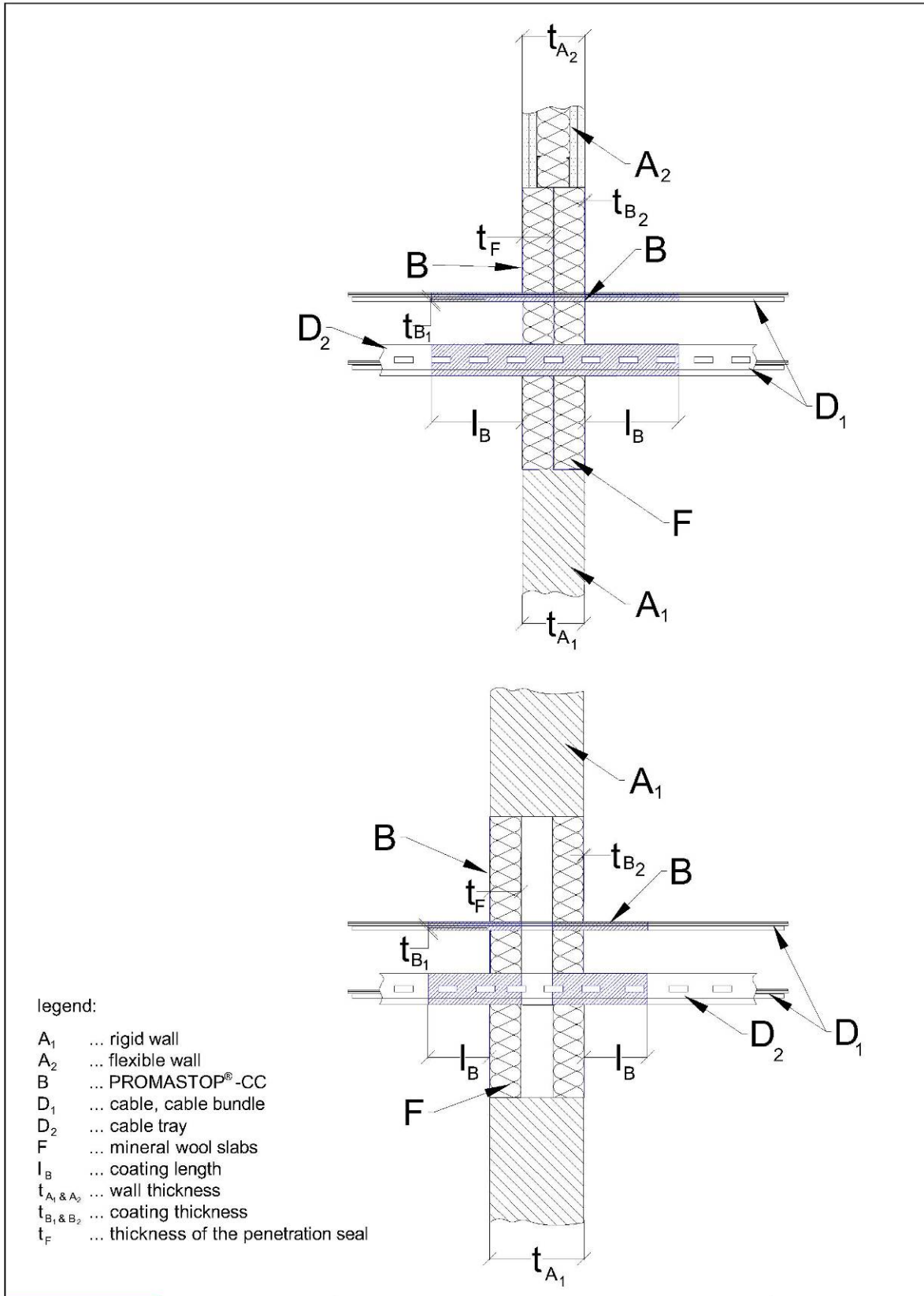

<p>PROMAT GmbH St.-Peter-Straße 25 4021 Linz / Austria Phone: +43 732 6912 - 3621 Fax: +43 732 6912 - 3740 www.promat.at technik@promat.at</p>	<p>PROMASTOP®-CC 2 x 50 mm seal penetrated by cables/cable bundles or cable trays in flexible and rigid wall constructions</p>				<p>modified by/on:</p>		
					<p>drawn by:</p> <p>KÖRBLER</p>		
					<p>drawing number:</p> <p>704.07</p>		
scale:	without	drawing format:	A4	date:	19.05.2016	division:	Technik

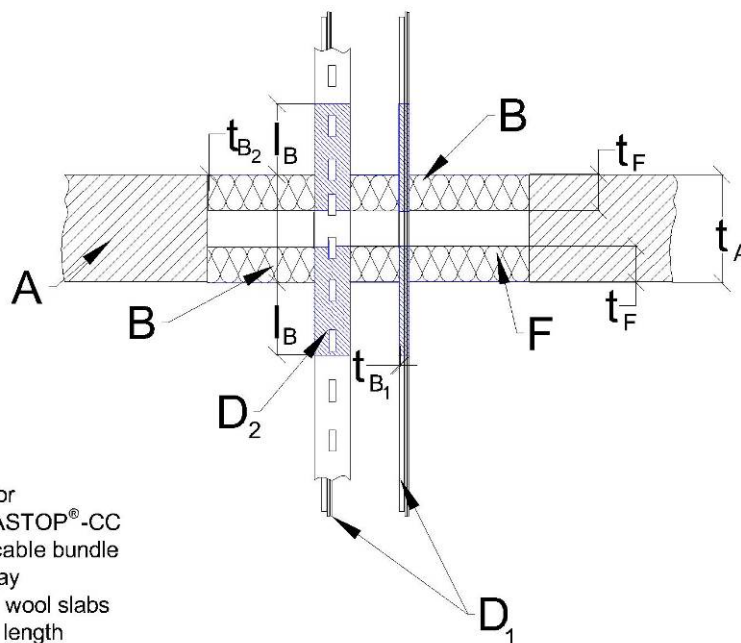
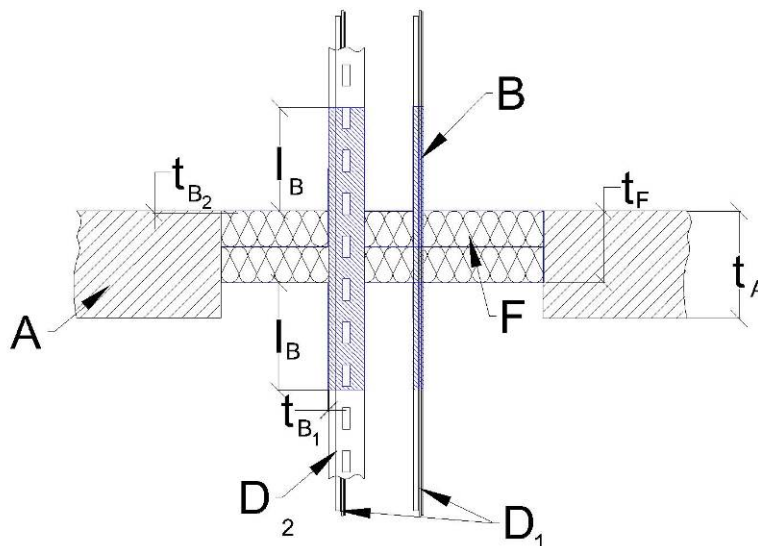

legend:

- A ... rigid floor
- B ... PROMASTOP®-CC
- D<sub>1</sub> ... cable, cable bundle
- D<sub>2</sub> ... cable tray
- F ... mineral wool slabs
- l<sub>B</sub> ... coating length
- t<sub>A</sub> ... wall thickness
- t<sub>B1</sub>, t<sub>B2</sub> ... coating thickness
- t<sub>F</sub> ... thickness of the penetration seal

**Promat**

PROMAT GmbH

St.-Peter-Straße 25  
4021 Linz / Austria  
Phone: +43 732 6912 - 3621  
Fax: +43 732 6912 - 3740  
www.promat.at  
technik@promat.at

PROMASTOP®-CC 2 x 50 mm seal penetrated by  
cables/cable bundles or cable trays in rigid  
floor constructions

scale: without drawing format: A4 date: 19.05.2016 division: Technik

modified by/on:

drawn by:

KÖRBLER

drawing number:

704.08

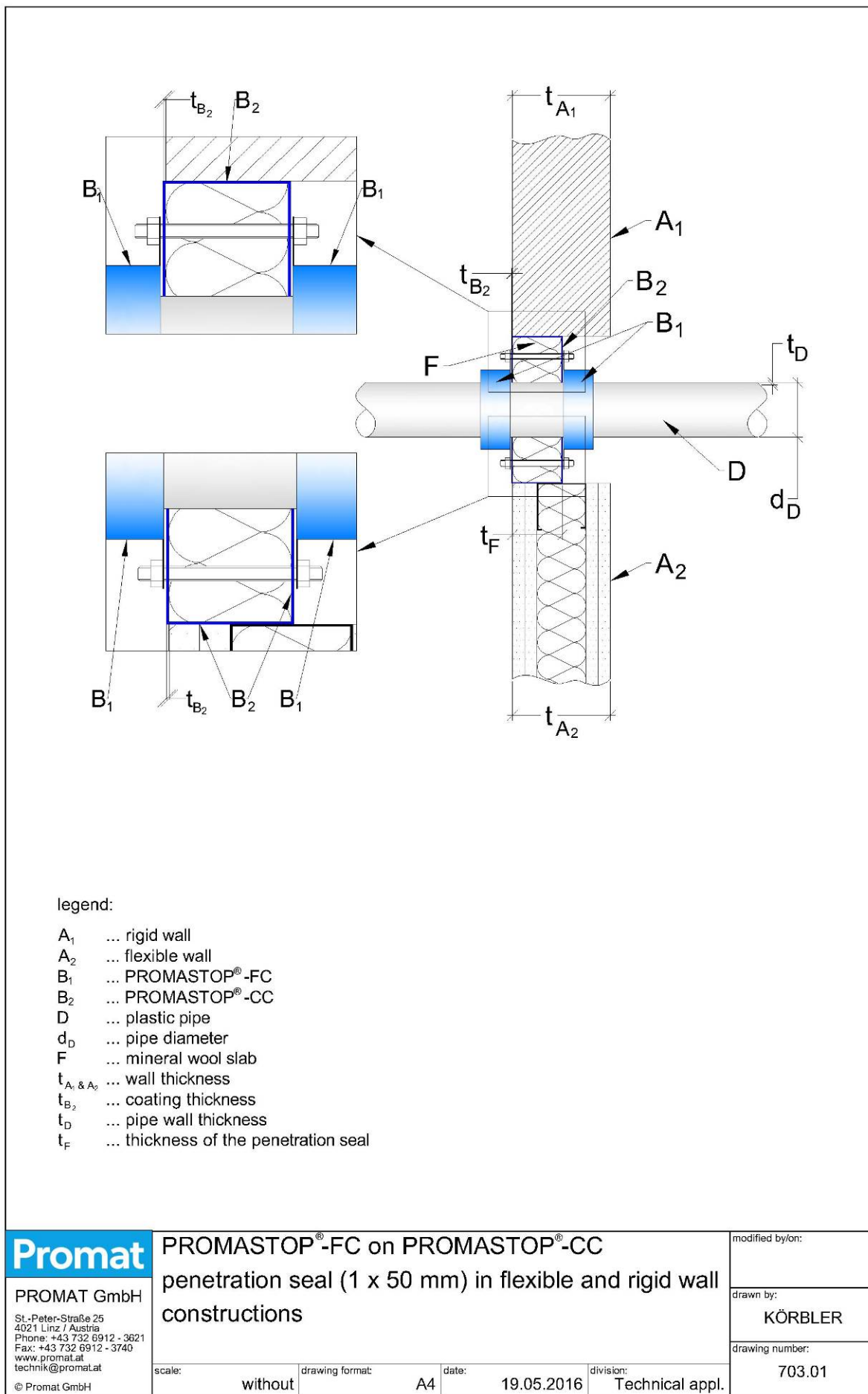

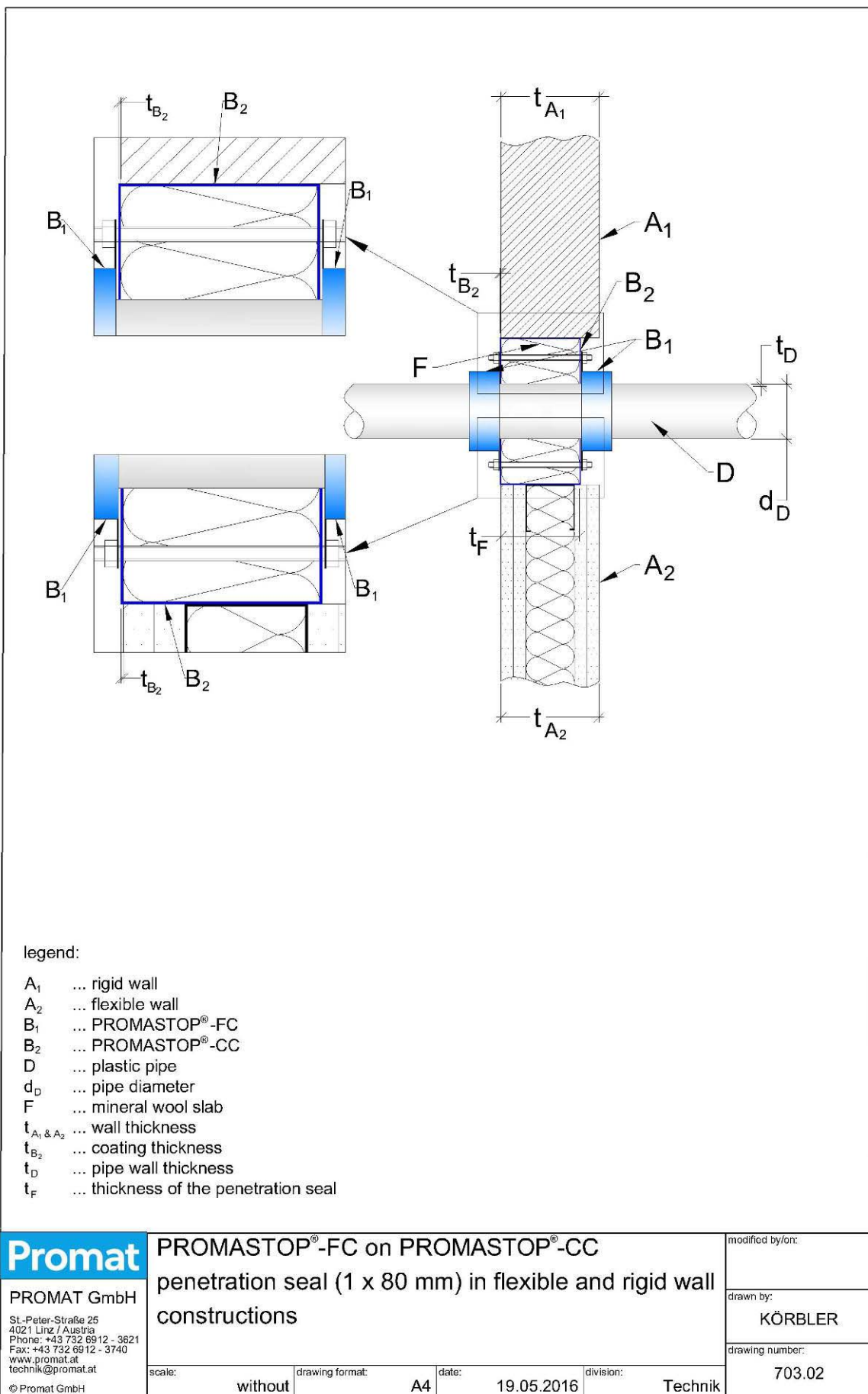

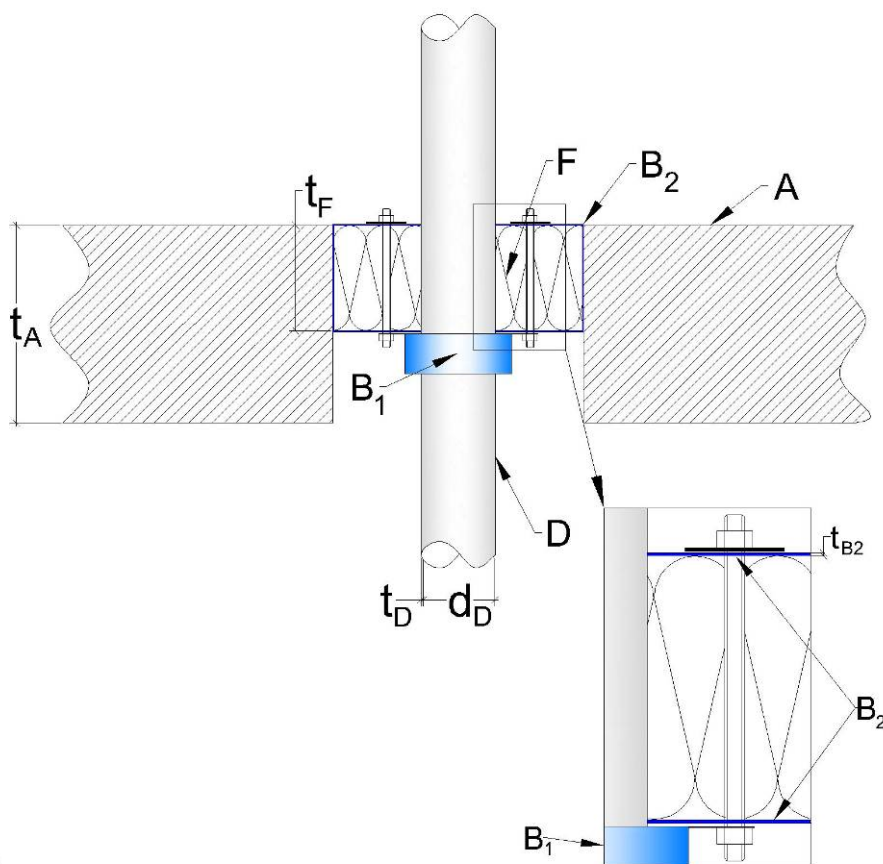

legend:

- A ... rigid floor
- B<sub>1</sub> ... PROMASTOP®-FC
- B<sub>2</sub> ... PROMASTOP®-CC
- D ... plastic pipe
- F ... mineral wool slab
- d<sub>D</sub> ... pipe diameter
- t<sub>A</sub> ... floor thickness
- t<sub>B<sub>2</sub></sub> ... coating thickness
- t<sub>D</sub> ... pipe wall thickness
- t<sub>F</sub> ... thickness of the penetration seal

**Promat**

PROMAT GmbH  
St.-Peter-Straße 25  
4021 Linz / Austria  
Phone: +43 732 6912 - 3621  
Fax: +43 732 6912 - 3740  
www.promat.at  
technik@promat.at  
© Promat GmbH

PROMASTOP®-FC on PROMASTOP®-CC  
penetration seal (1 x 80 mm) in rigid floor  
constructions

scale:	without	drawing format:	A4	date:	19.05.2016	division:	Technik
--------	---------	-----------------	----	-------	------------	-----------	---------

modified by/on:

drawn by:

KÖRBLER

drawing number:

703.06

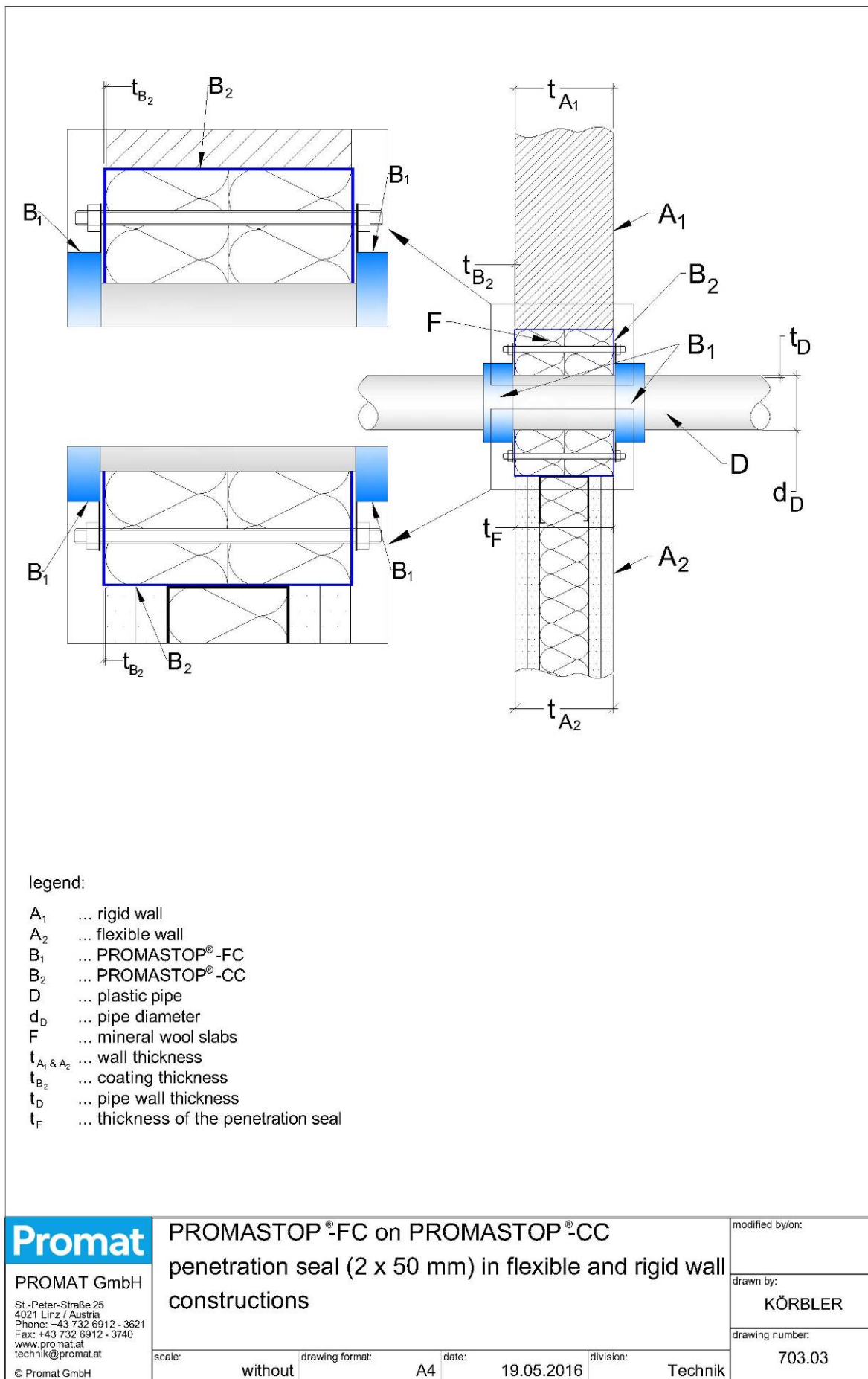



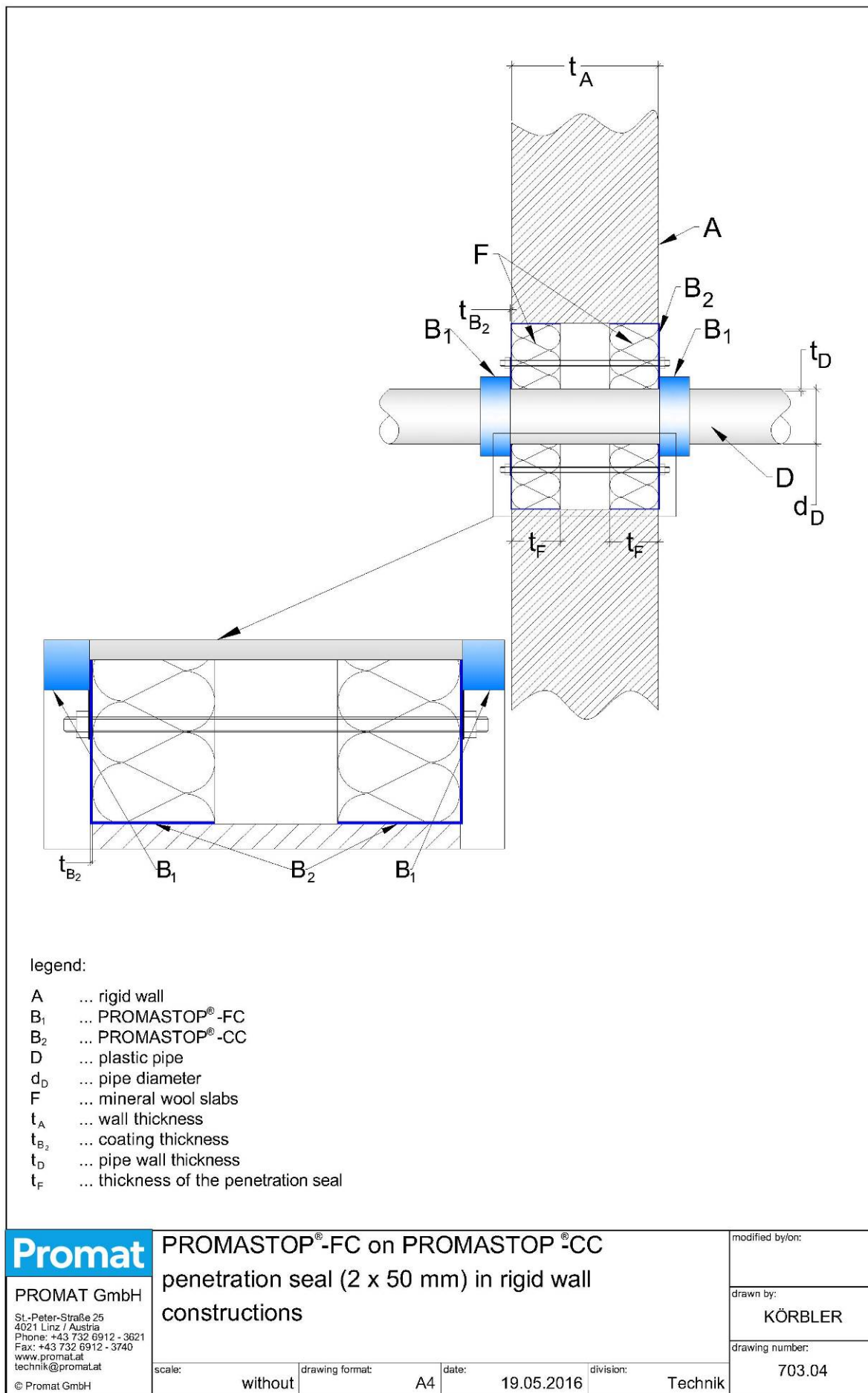

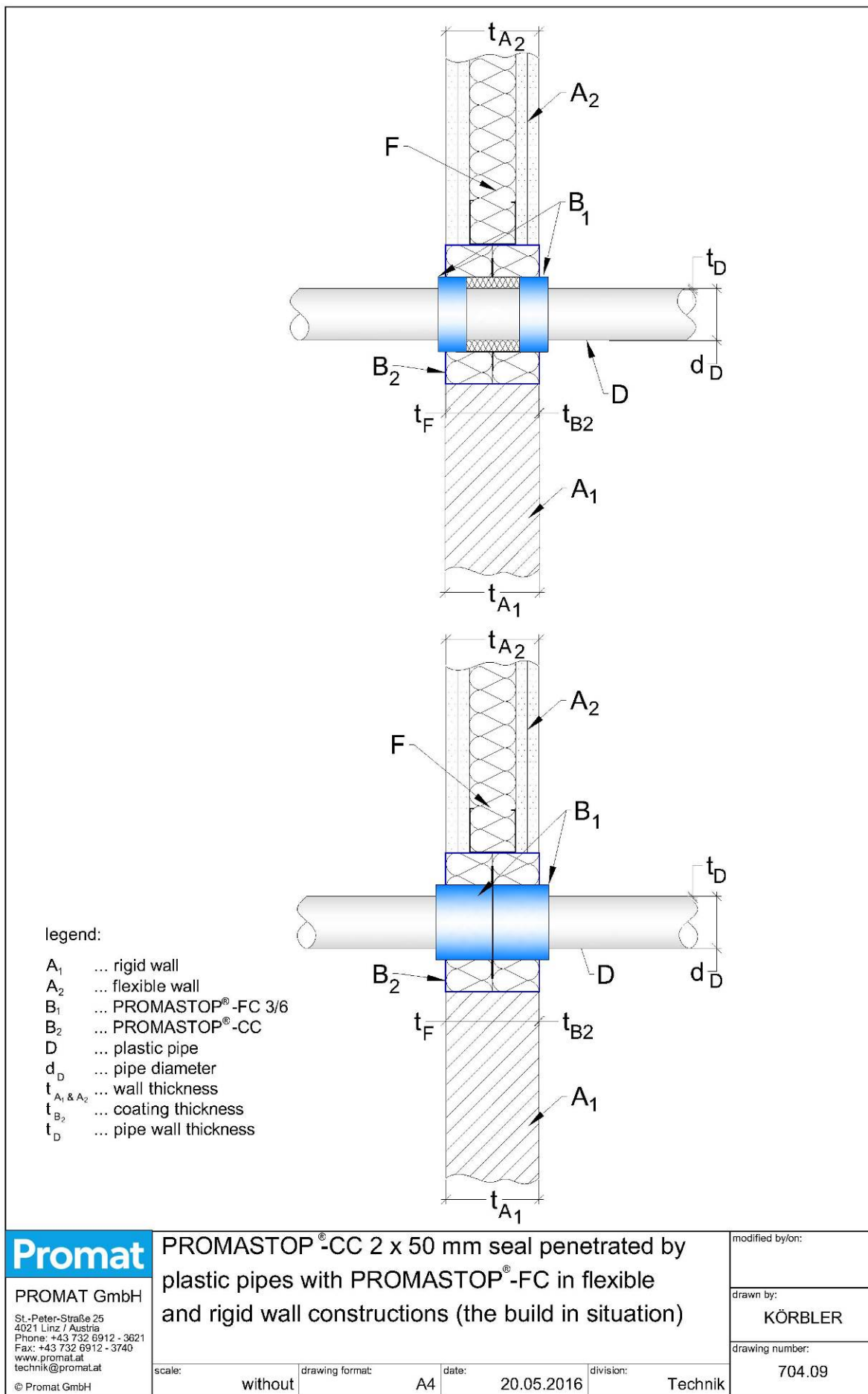

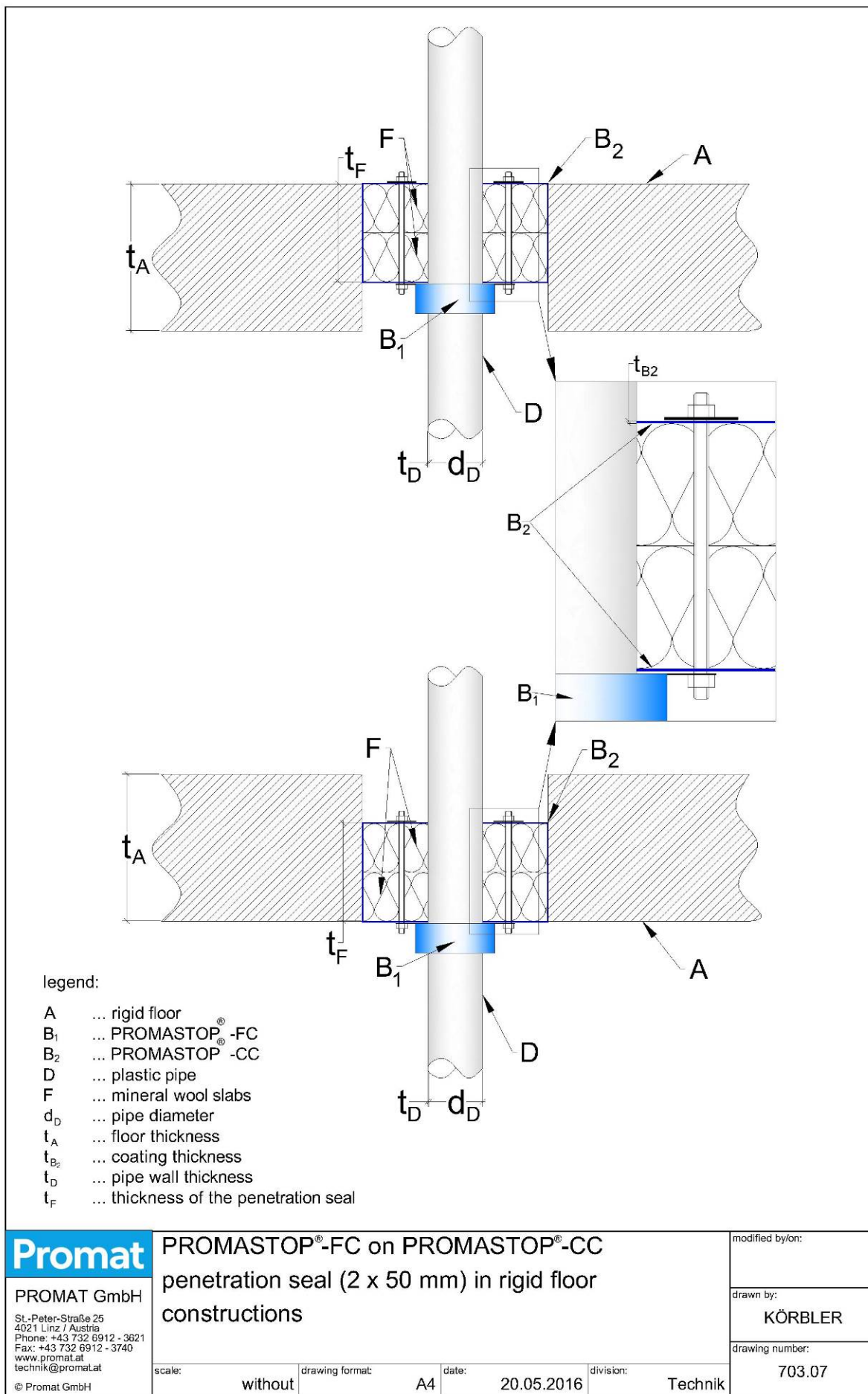

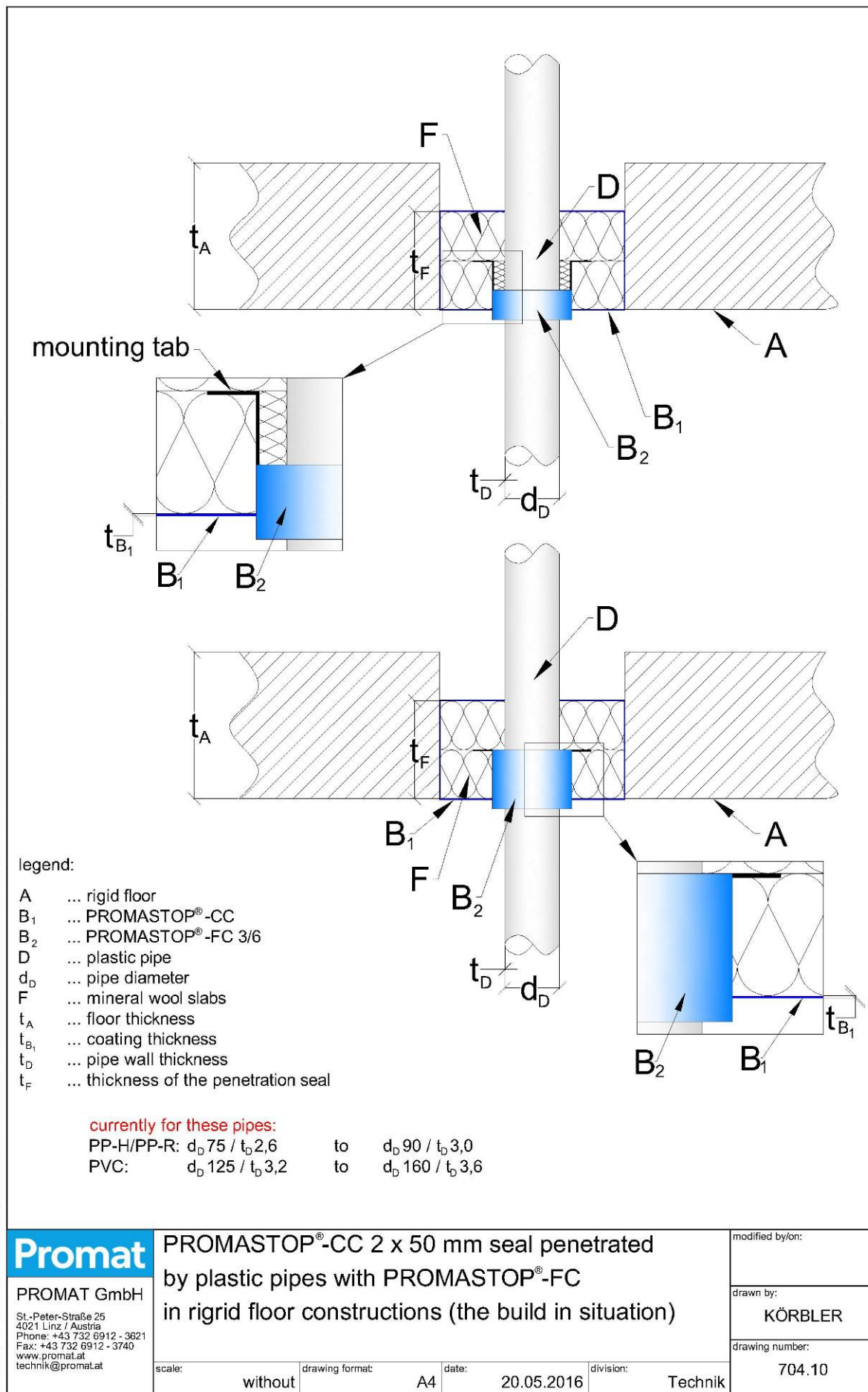

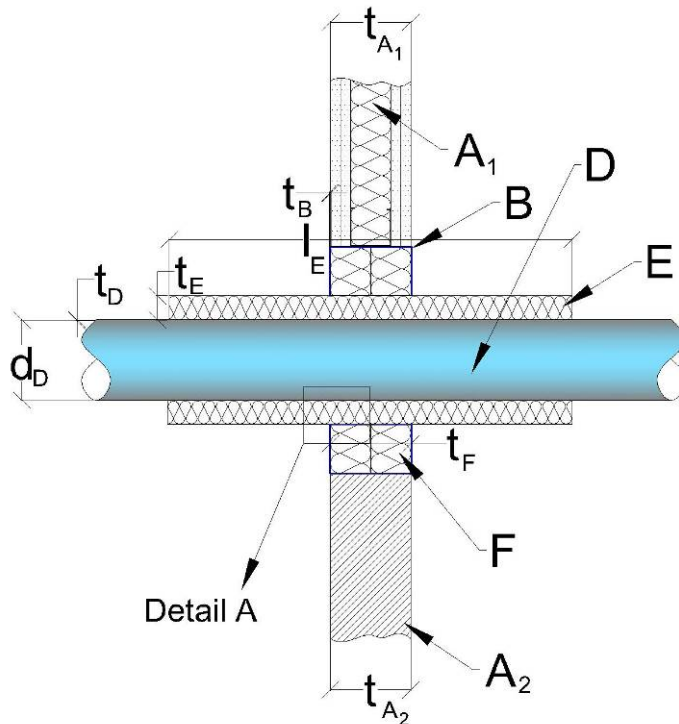

Detail A

Detail A

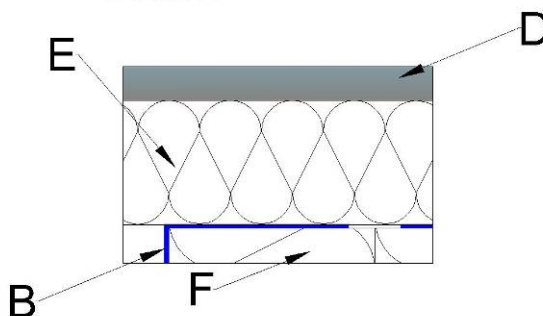

legend:

- A<sub>1</sub> ... flexible wall
- A<sub>2</sub> ... rigid wall
- B<sub>1</sub> ... PROMASTOP®-CC
- D ... metal pipe
- E ... insulation
- d<sub>D</sub> ... pipe diameter
- F ... mineral wool slabs
- t<sub>A<sub>1</sub> & A<sub>2</sub></sub> ... wall thickness
- t<sub>B<sub>1</sub></sub> ... coating thickness
- t<sub>D</sub> ... pipe wall thickness
- t<sub>F</sub> ... thickness of the penetration seal
- t<sub>E</sub> ... insulation thickness
- l<sub>E</sub> ... insulation length

**Promat**

PROMAT GmbH  
St.-Peter-Straße 25  
4021 Linz / Austria  
Phone: +43 732 6912 - 3621  
Fax: +43 732 6912 - 3740  
www.promat.at  
technik@promat.at

PROMASTOP®-CC 2 x 50 mm seal penetrated  
by metal pipes with non-combustible insulation  
in flexible and rigid wall constructions

modified by/on:

drawn by:

KÖRBLER

drawing number:

704.11

scale:

without

drawing format:

A4

date:

24.05.2016

division:

Technik

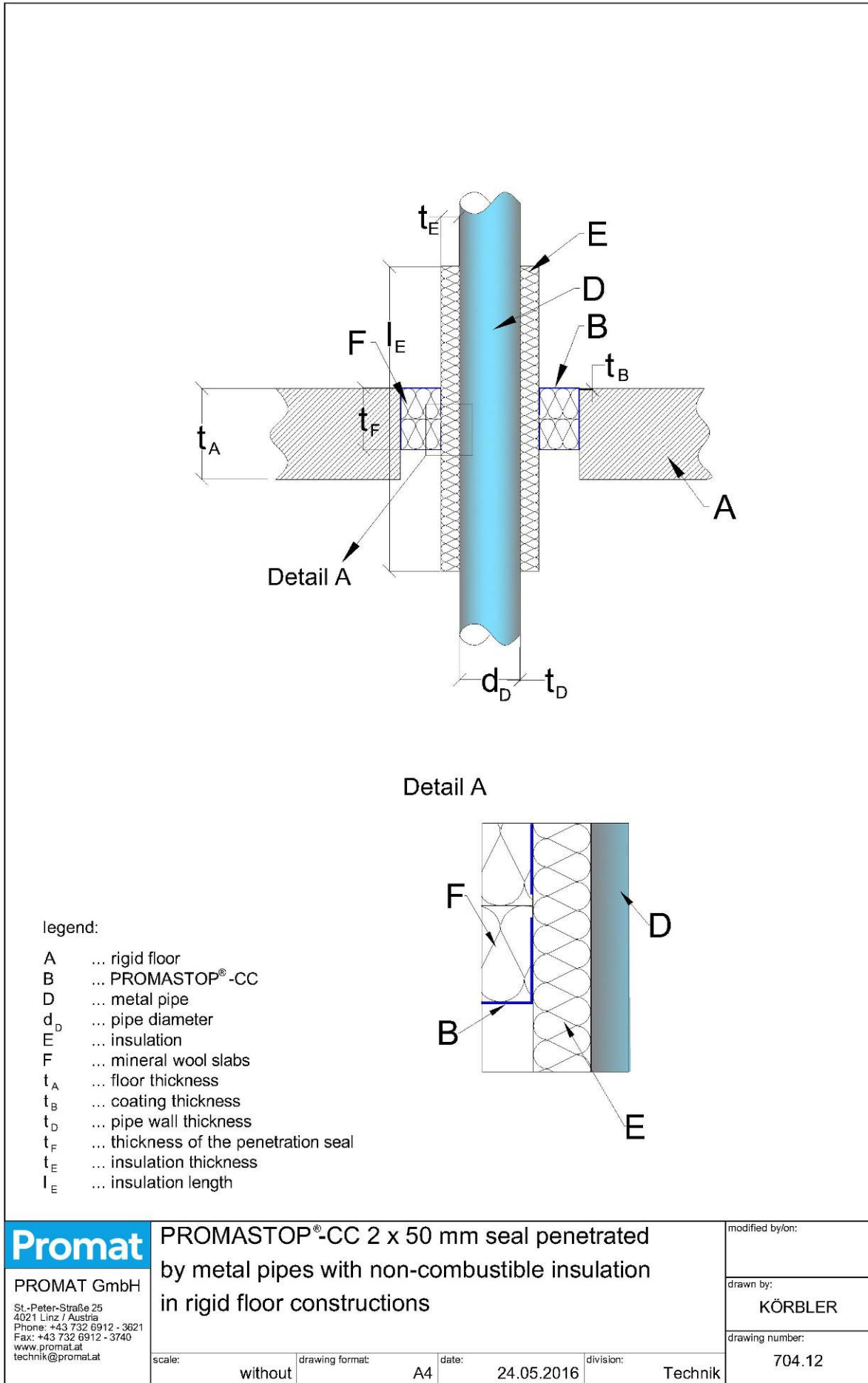

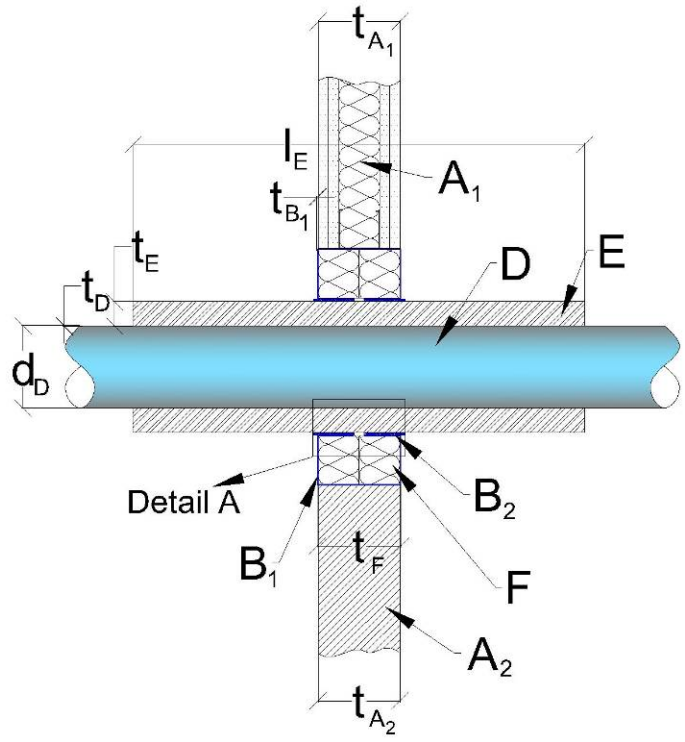

Number of layers PROMASTOP®-W:  
see classification report or ETA

legend:

- A<sub>1</sub> ... flexible wall
- A<sub>2</sub> ... rigid wall
- B<sub>1</sub> ... PROMASTOP®-CC
- B<sub>2</sub> ... PROMASTOP®-W
- D ... metal pipe
- E ... insulation
- d<sub>D</sub> ... pipe diameter
- F ... mineral wool slabs
- t<sub>A<sub>1</sub> & A<sub>2</sub></sub> ... wall thickness
- t<sub>B<sub>1</sub></sub> ... coating thickness
- t<sub>D</sub> ... pipe wall thickness
- t<sub>F</sub> ... thickness of the penetration seal
- t<sub>E</sub> ... insulation thickness
- l<sub>E</sub> ... insulation length

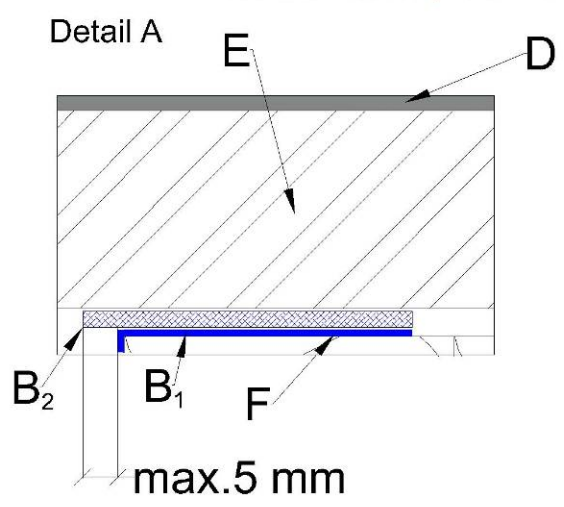

	<b>PROMASTOP®-CC 2 x 50 mm seal penetrated by metal pipes with PROMASTOP®-W and combustible insulation in flexible and rigid wall constructions</b>				modified by/on:
	PROMAT GmbH St.-Peter-Straße 25 4021 Linz / Austria Phone: +43 732 6912 - 3621 Fax: +43 732 6912 - 3740 www.promat.at technik@promat.at				drawn by: <b>KÖRBLER</b>
scale: without	drawing format: A4	date: 20.05.2016	division: Technik	drawing number: <b>704.13</b>	

electronic copy

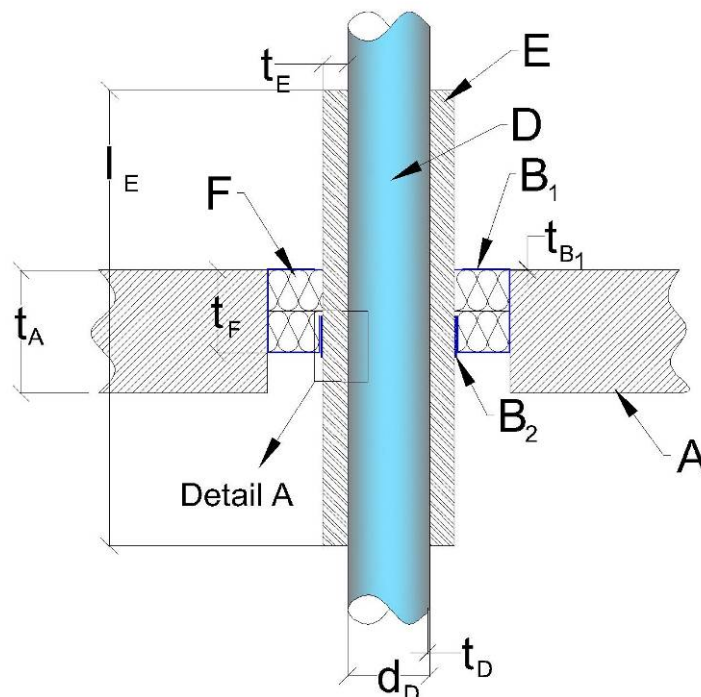

Number of layers PROMASTOP®-W:  
see classification report or ETA

Detail A

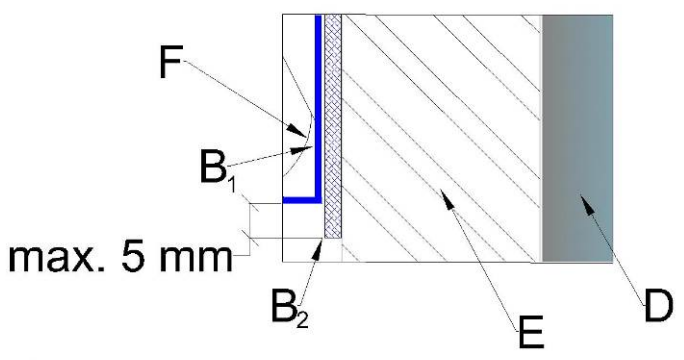

- legend:
- A ... rigid floor
  - B<sub>1</sub> ... PROMASTOP®-CC
  - B<sub>2</sub> ... PROMASTOP®-W
  - D ... metal pipe
  - d<sub>D</sub> ... pipe diameter
  - E ... insulation
  - F ... mineral wool slabs
  - t<sub>A</sub> ... floor thickness
  - t<sub>B</sub> ... coating thickness
  - t<sub>D</sub> ... pipe wall thickness
  - t<sub>F</sub> ... thickness of the penetration seal
  - t<sub>E</sub> ... insulation thickness
  - l<sub>E</sub> ... insulation length

<b>Promat</b> PROMAT GmbH St.-Peter-Straße 25 4021 Linz / Austria Phone: +43 732 6912 - 3621 Fax: +43 732 6912 - 3740 www.promat.at technik@promat.at	PROMASTOP®-CC 2 x 50 mm seal penetrated by metal pipes with PROMASTOP -W and combustible insulation in rigid floor constructions			modified by/on:
	scale: without	drawing format: A4	date: 20.05.2016	division: Technik
				drawing number: 704.14



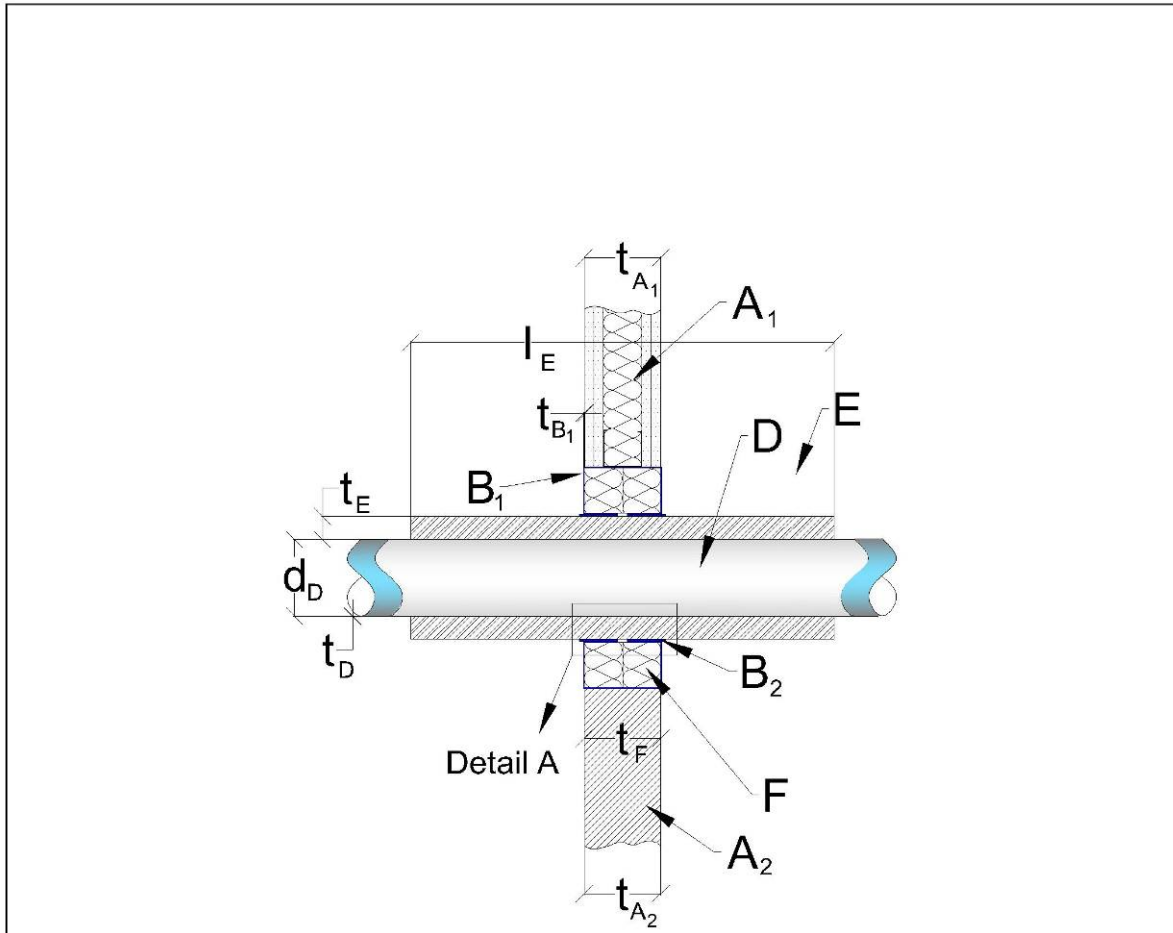

Number of layers PROMASTOP®-W:  
see classification report or ETA

legend:

- A<sub>1</sub> ... flexible wall
- A<sub>2</sub> ... rigid wall
- B<sub>1</sub> ... PROMASTOP®-CC
- B<sub>2</sub> ... PROMASTOP®-W
- D ... plastic-aluminium compound pipe
- E ... insulation
- d<sub>D</sub> ... pipe diameter
- F ... mineral wool slabs
- t<sub>A<sub>1</sub> & A<sub>2</sub></sub> ... wall thickness
- t<sub>B<sub>1</sub></sub> ... coating thickness
- t<sub>D</sub> ... pipe wall thickness
- t<sub>F</sub> ... thickness of the penetration seal
- t<sub>E</sub> ... insulation thickness
- l<sub>E</sub> ... insulation length

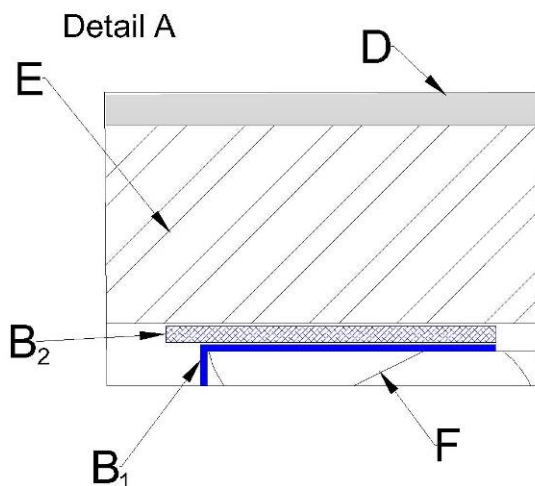

	<b>PROMASTOP®-CC 2 x 50 mm seal penetrated by plastic-aluminium compound pipes with PROMASTOP®-W and combustible insulation in flexible and rigid wall constructions</b>				modified by/on:			
	PROMAT GmbH St.-Pete-Straße 25 4021 Linz / Austria Phone: +43 732 6912 - 3621 Fax: +43 732 6912 - 3740 www.promat.at technik@promat.at				drawn by: <b>KÖRBLER</b>			
scale:	without	drawing format:	A4	date:	25.05.2016	division:	Technik	drawing number: <b>704.15</b>

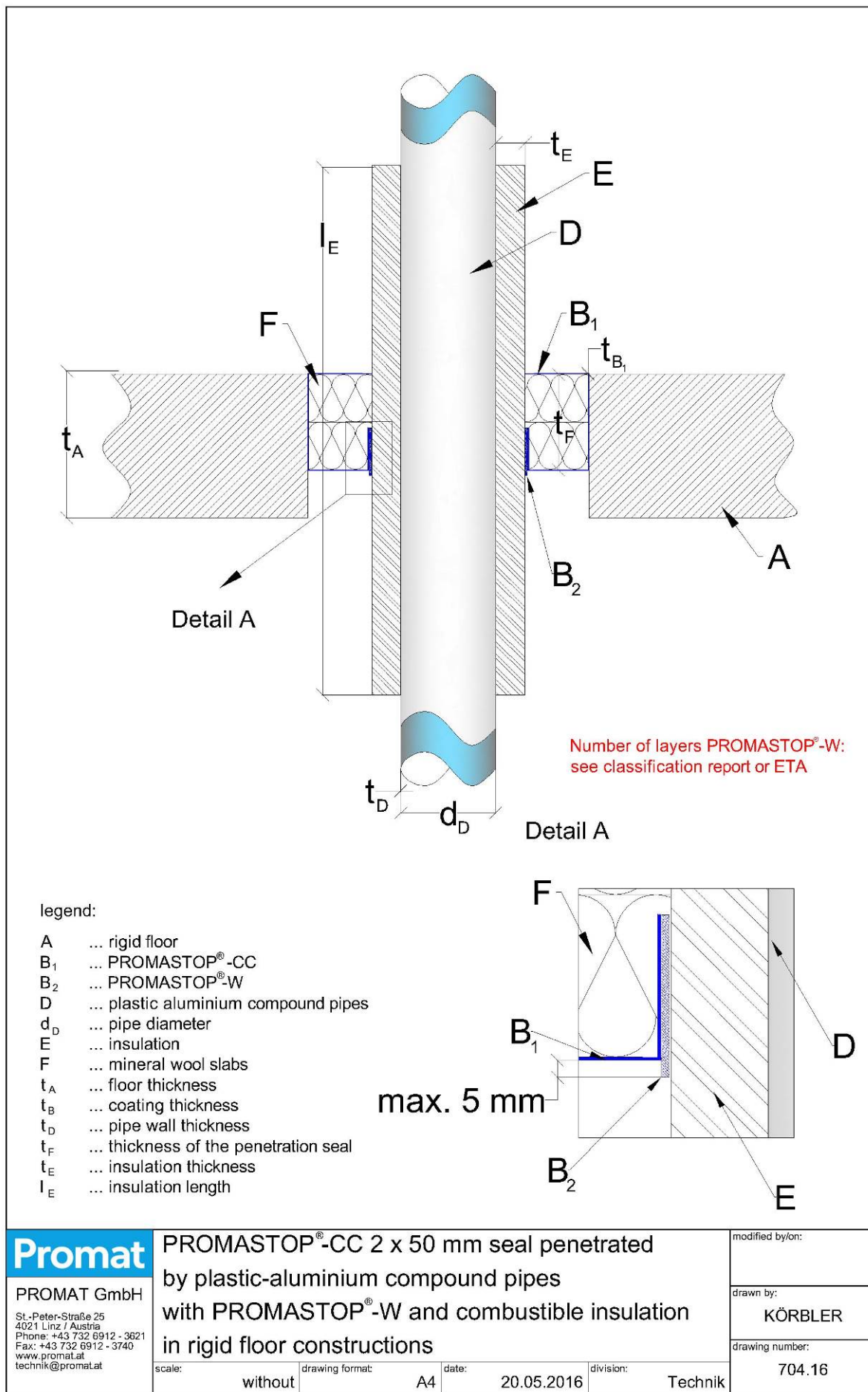

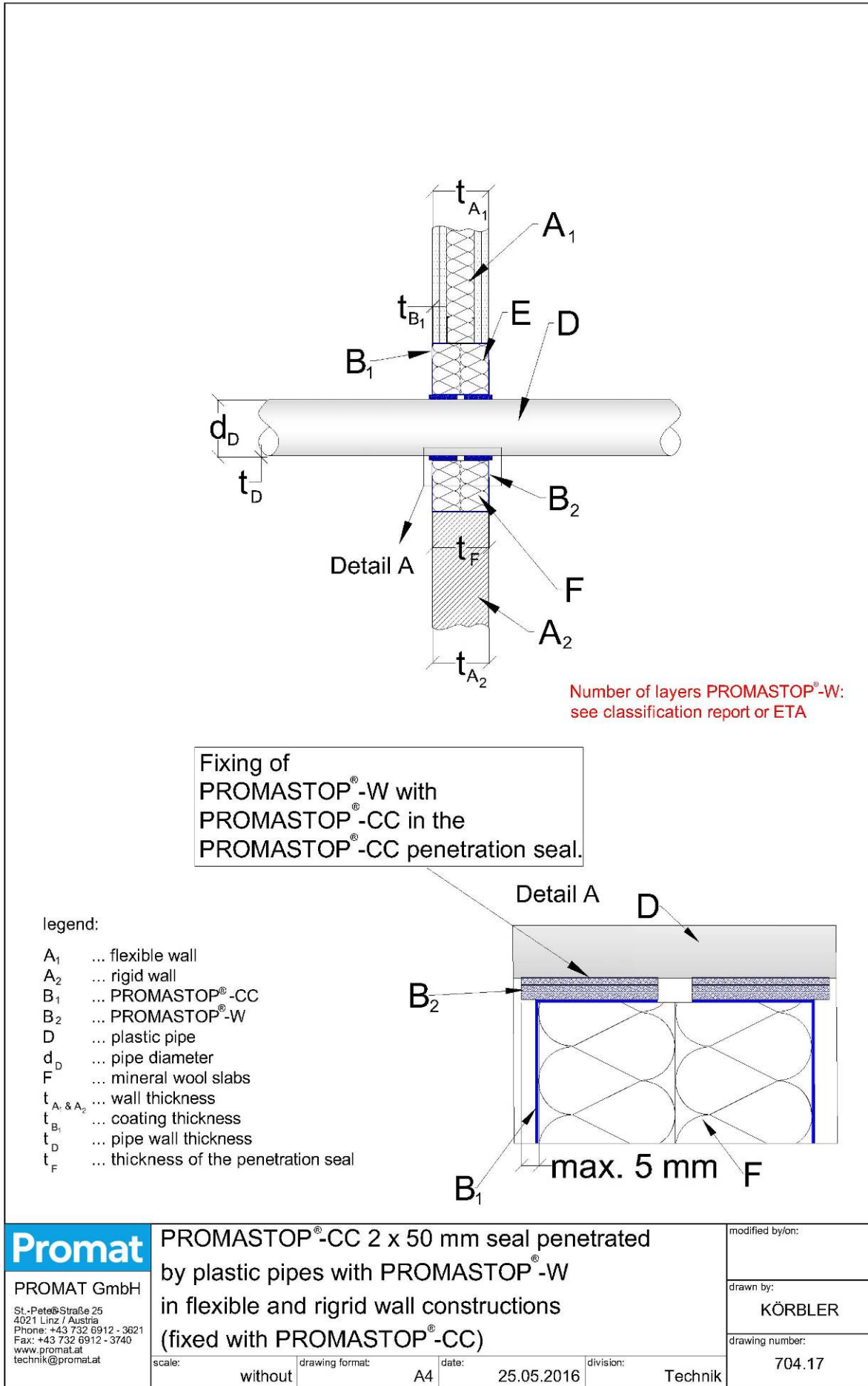

electronic copy electronic copy electronic copy electronic copy electronic copy electronic copy electronic copy electronic copy electronic copy electronic copy

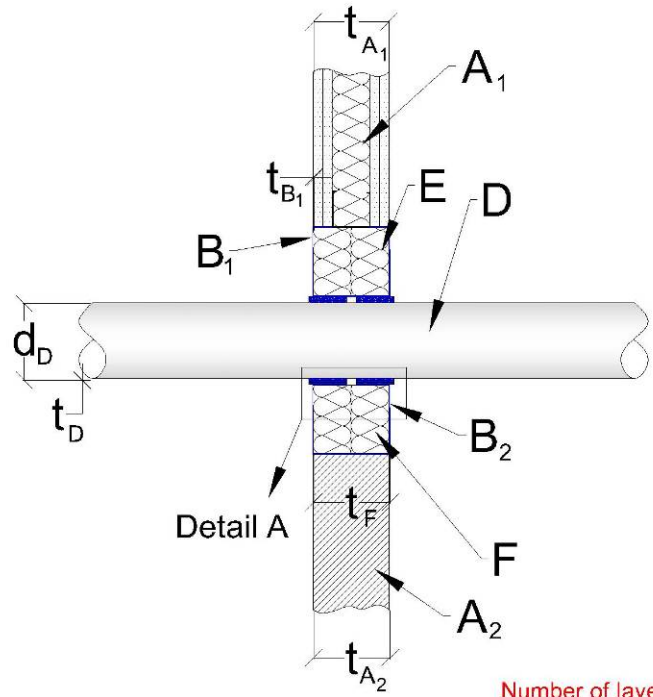

Number of layers PROMASTOP®-W:  
see classification report or ETA

Fixing of  
PROMASTOP®-W with  
PROMASEAL®-A in the  
PROMASTOP®-CC penetration seal.

legend:

- A<sub>1</sub> ... flexible wall
- A<sub>2</sub> ... rigid wall
- B<sub>1</sub> ... PROMASTOP®-CC
- B<sub>2</sub> ... PROMASTOP®-W
- B<sub>4</sub> ... PROMASEAL®-A
- D ... plastic pipe
- d<sub>D</sub> ... pipe diameter
- F ... mineral wool slabs
- t<sub>A<sub>1</sub> & A<sub>2</sub></sub> ... wall thickness
- t<sub>B<sub>1</sub></sub> ... coating thickness
- t<sub>D</sub> ... pipe wall thickness
- t<sub>F</sub> ... thickness of the penetration seal

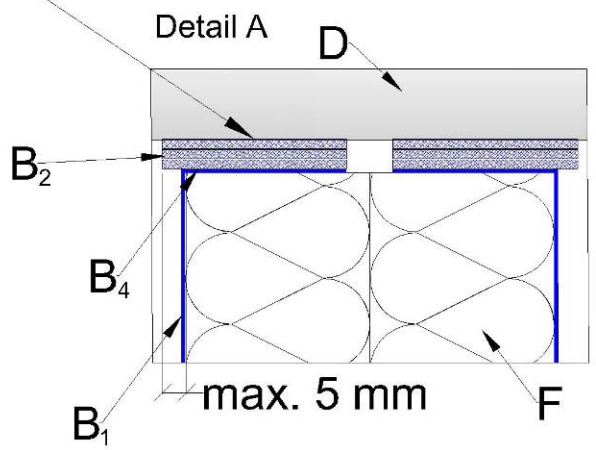

	<b>PROMASTOP®-CC 2 x 50 mm penetrated by plastic pipes with PROMASTOP®-W in flexible and rigid wall constructions (fixed with PROMASEAL®-A)</b>				modified by/on:
	PROMAT GmbH St.-Pete-Strasse 25 4021 Linz / Austria Phone: +43 732 6912 - 3621 Fax: +43 732 6912 - 3740 www.promat.at technik@promat.at				drawn by: <b>KÖRBLER</b>
scale: without	drawing format: A4	date: 25.05.2016	division: Technik	drawing number: 704.18	

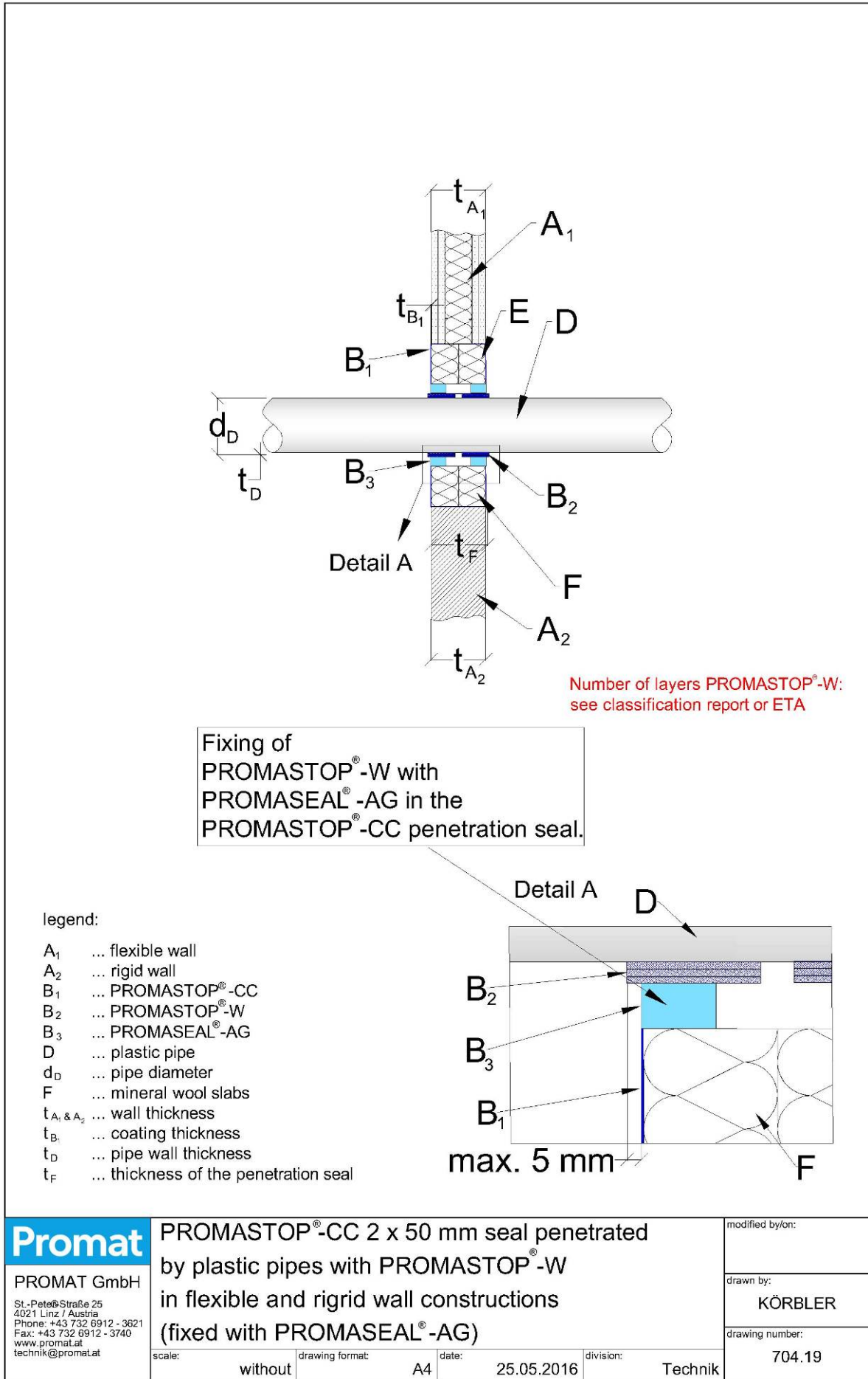

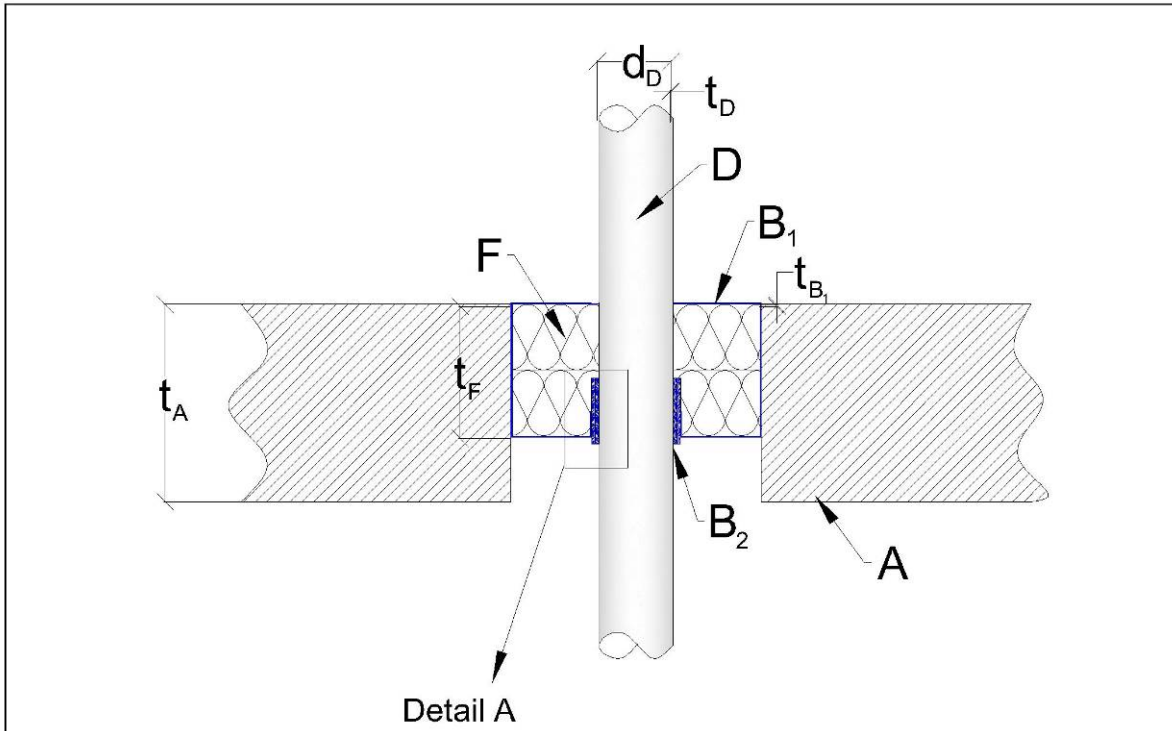

Fixing of PROMASTOP®-W with PROMASTOP®-CC in the PROMASTOP®-CC penetration seal.

Number of layers PROMASTOP®-W: see classification report or ETA

legend:

- A ... rigid floor
- B<sub>1</sub> ... PROMASTOP®-CC
- B<sub>2</sub> ... PROMASTOP®-W
- D ... plastic pipe
- d<sub>D</sub> ... pipe diameter
- F ... mineral wool slabs
- t<sub>A</sub> ... floor thickness
- t<sub>B1</sub> ... coating thickness
- t<sub>D</sub> ... pipe wall thickness
- t<sub>F</sub> ... thickness of the penetration seal

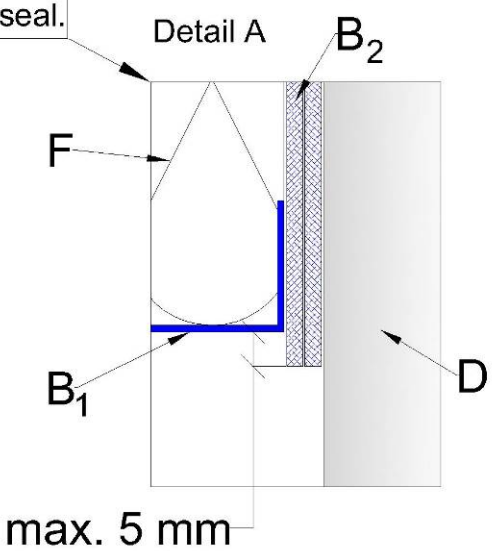

	<b>PROMASTOP®-CC 2 x 50 mm seal penetrated by plastic pipes with PROMASTOP®-W in rigid wall constructions (fixed with PROMASTOP®-CC)</b>			modified by/on:
	PROMAT GmbH St.-Peter-Strasse 25 4021 Linz / Austria Phone: +43 732 6912 - 3621 Fax: +43 732 6912 - 3740 www.promat.at technik@promat.at			drawn by: <b>KÖRBLER</b>
scale: without	drawing format: A4	date: 24.05.2016	division: Technik	drawing number: 704.20

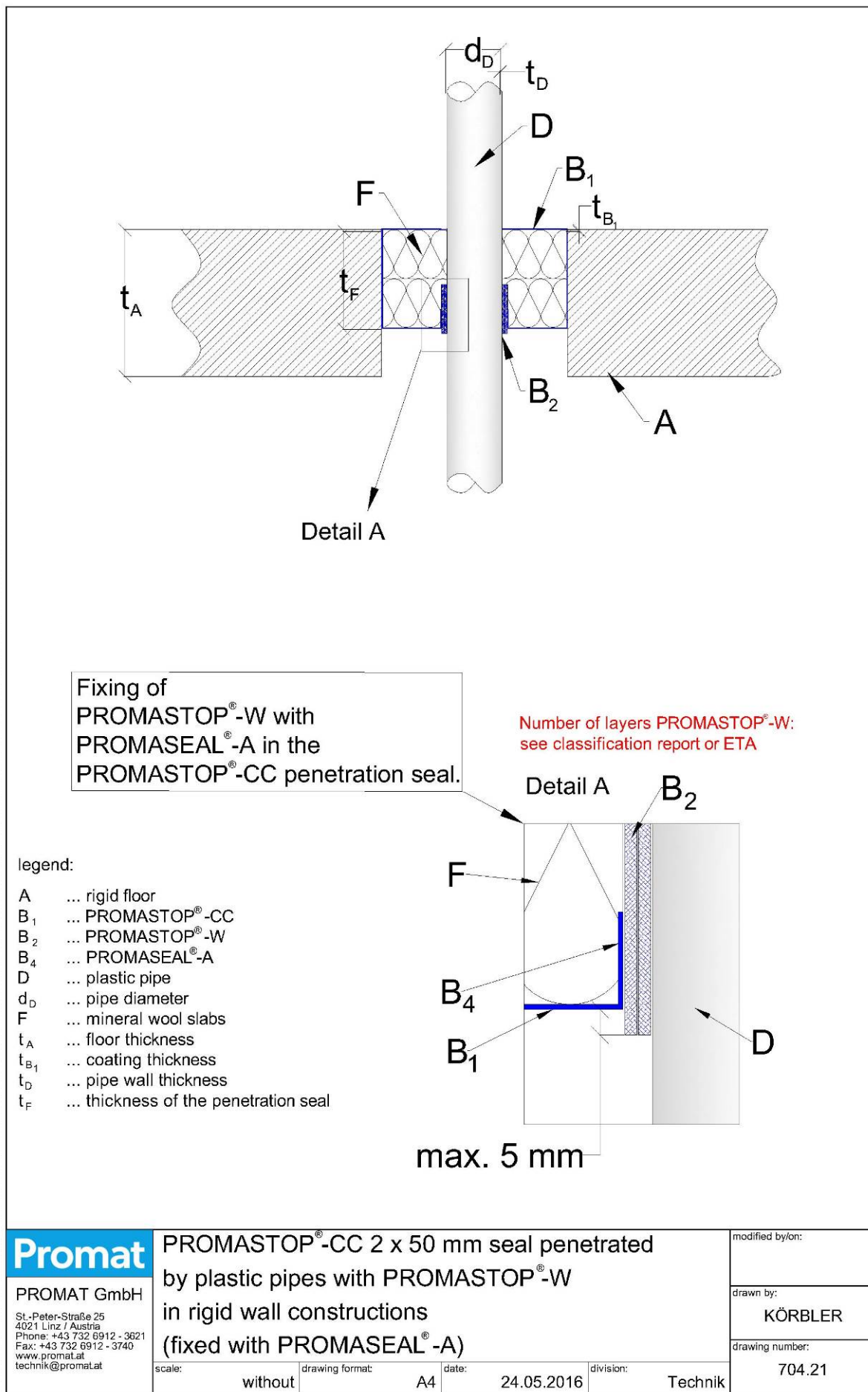

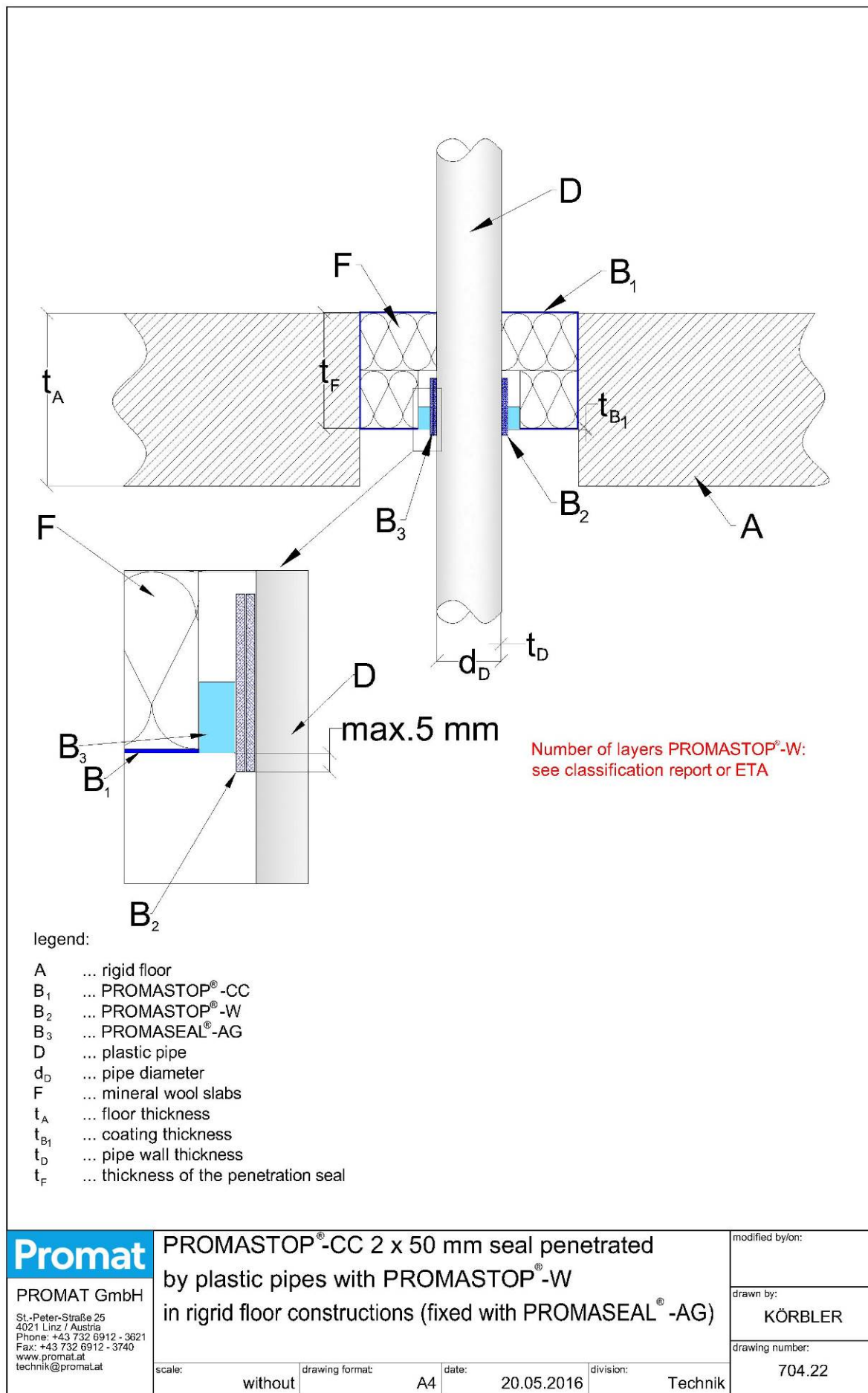



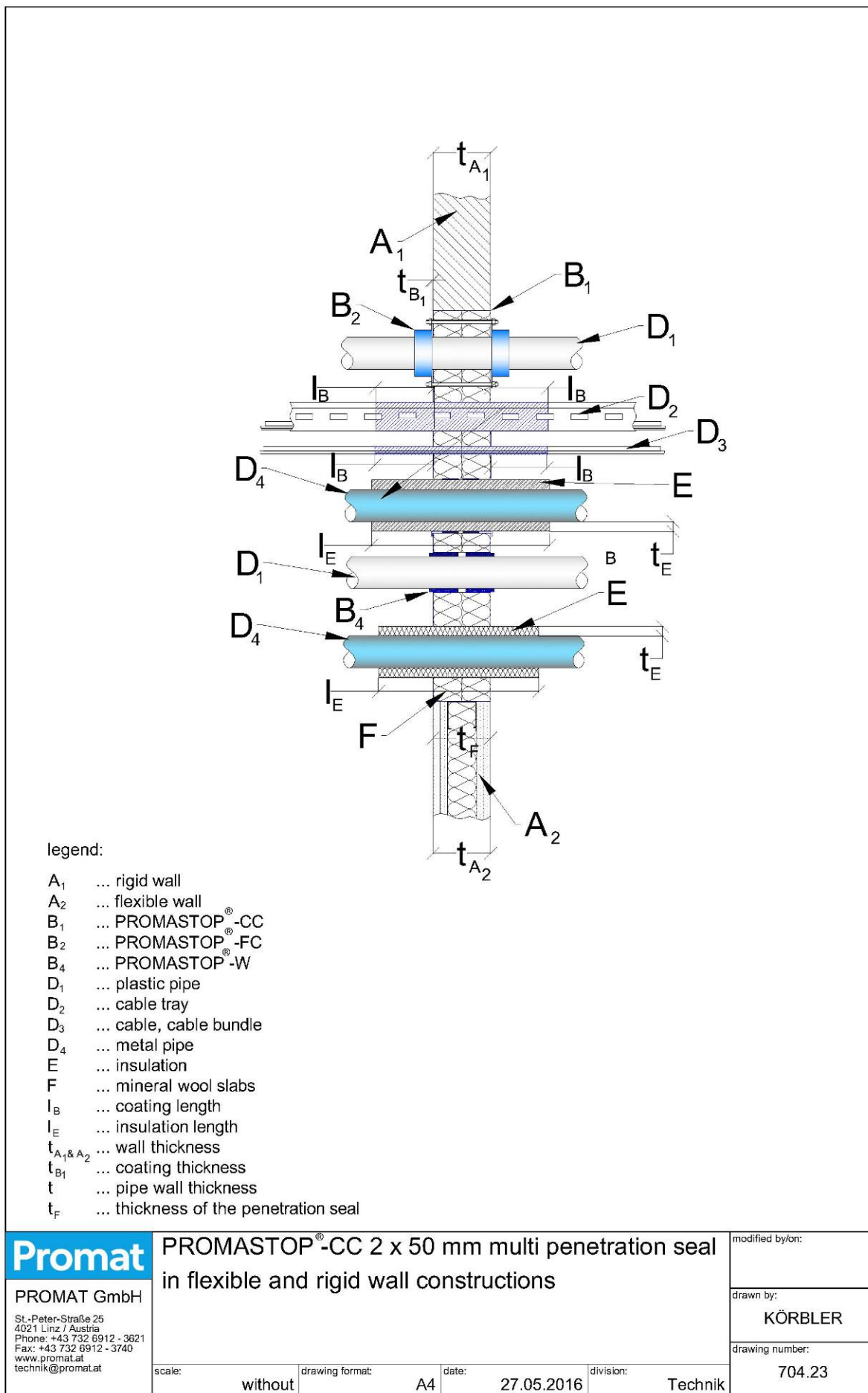

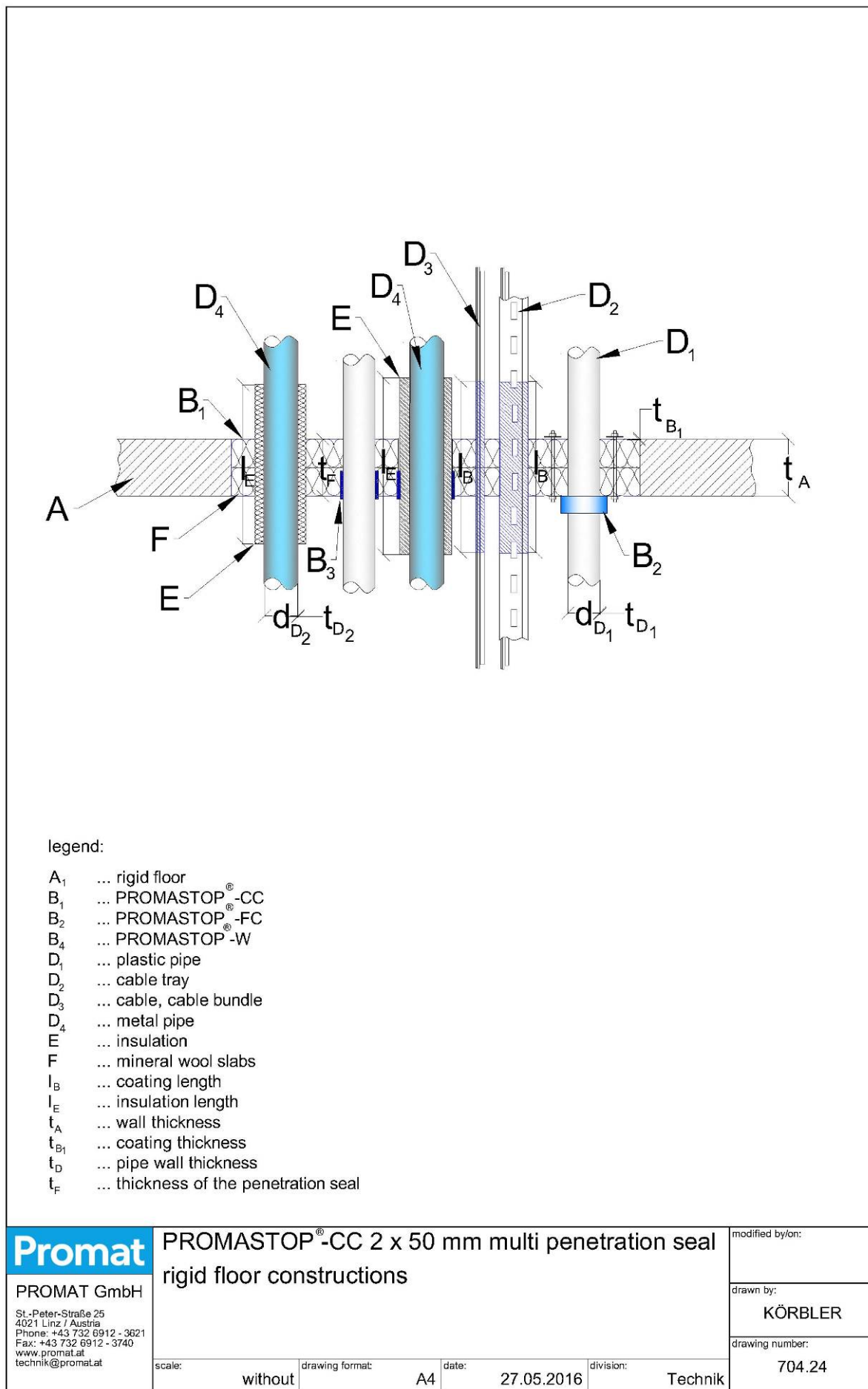

**ANNEX 5**  
**MAXIMUM DIMENSIONS OF PROMASTOP®-CC 1 x 50 mm PENETRATION SEAL IN RIGID FLOORS**

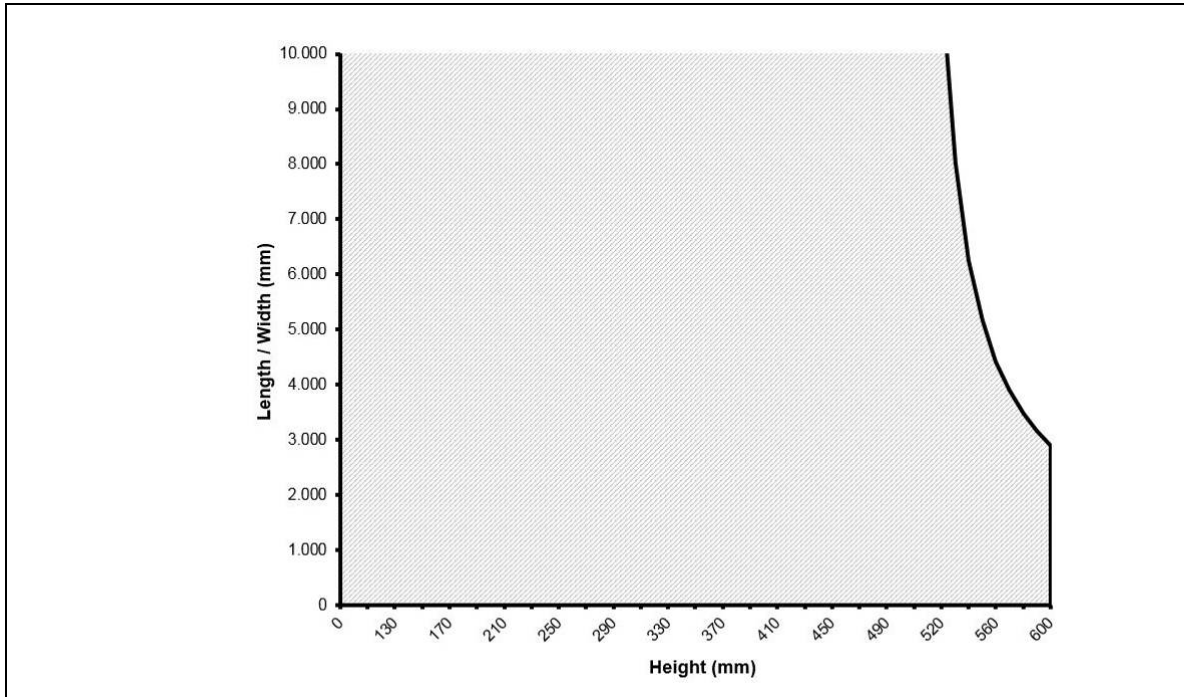

The maximum height of the penetration seal in rigid floors is 600 mm.

The maximum length (width) of the penetration seal in rigid floors has to be calculated as follows:

$$Length \ (Width) = \frac{Height}{(((c_{tested} / 2) * Height) - 1)}$$

$$c_{tested} = \frac{Perimeter \ length_{tested}}{Seal \ area_{tested}} = 4,023 \ m / m^2; \ resp. \ 0,004023 \ mm / mm^2$$

The minimum perimeter length to seal area ratio of the penetration seal in rigid floors is 4,023 m/m<sup>2</sup>, resp. 0,004023 mm/mm<sup>2</sup>.

*c<sub>tested</sub>* was calculated from the dimensions of the tested penetration seal (2900 mm x 600 mm).

The area on the left side of the graph gives an overview of all possible combinations of length (width) and height where the minimum perimeter length to seal area ratio is ≥ *c<sub>tested</sub>*.

For a length (width) of e.g. 2900 mm the allowed height is 600 mm; for a length (width) of e.g. 4770 mm the allowed height is 555 mm.

For a height smaller than 498 mm no limitation of length (width) is required.

Note: The dimensions of the graph are not true to scale.

**MAXIMUM DIMENSIONS OF PROMASTOP®-CC 1 x 80 mm PENETRATION SEAL IN RIGID FLOORS**

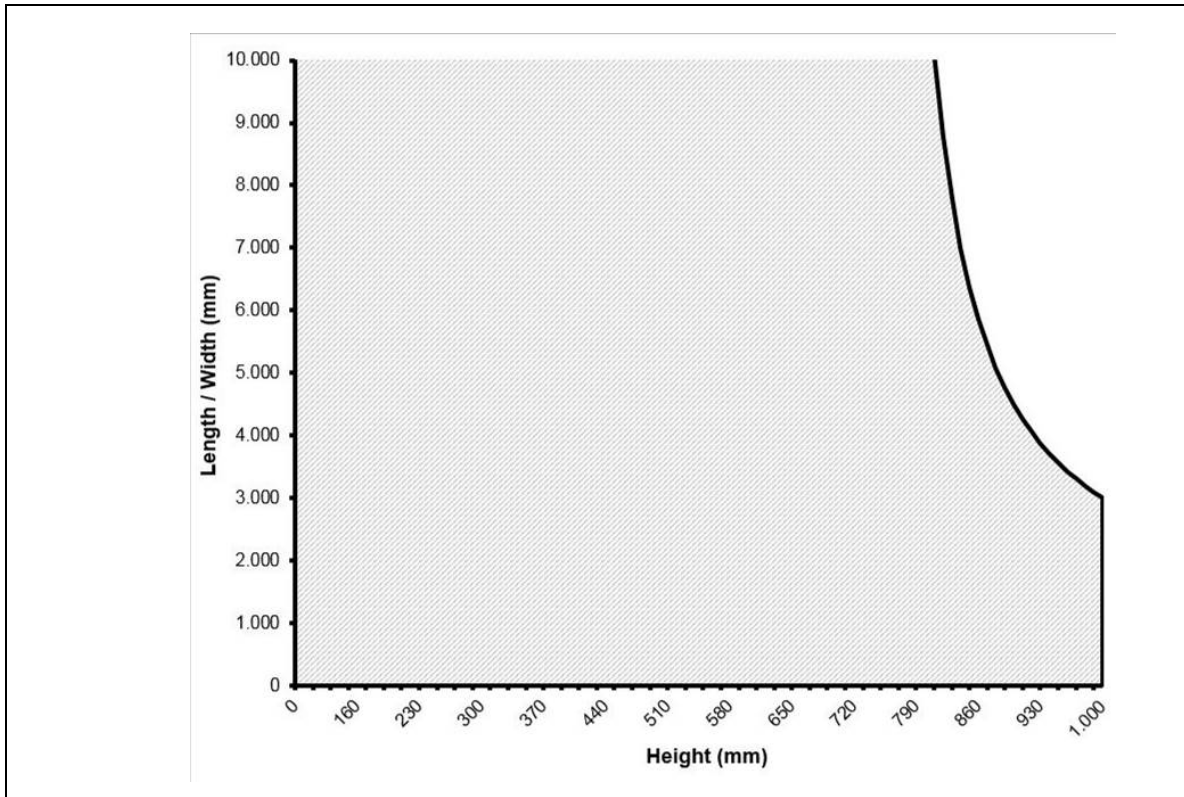

The maximum height of the penetration seal in rigid floors is 1000 mm.

The maximum length (width) of the penetration seal in rigid floors has to be calculated as follows:

$$Length \ (Width) = \frac{Height}{(((c_{tested} / 2) * Height) - 1)}$$

$$c_{tested} = \frac{Perimeter \ length_{tested}}{Seal \ area_{tested}} = 2,667 \ m / m^2; \ resp. \ 0,002667 \ mm / mm^2$$

The minimum perimeter length to seal area ratio of the penetration seal in rigid floors is 2,667 m/m<sup>2</sup>, resp. 0,002667 mm/mm<sup>2</sup>.

c<sub>tested</sub> was calculated from the dimensions of the tested penetration seal (3000 mm x 1000 mm).

The area on the left side of the graph gives an overview of all possible combinations of length (width) and height where the minimum perimeter length to seal area ratio is ≥ c<sub>tested</sub>.

For a length (width) of e.g. 3000 mm the allowed height is 1000 mm; for a length (width) of e.g. 4500 mm the allowed height is 900 mm.

For a height smaller than 751 mm no limitation of length (width) is required.

Note: The dimensions of the graph are not true to scale.

**MAXIMUM DIMENSIONS OF PROMASTOP®-CC 2 x 50 mm PENETRATION SEAL IN RIGID FLOORS**

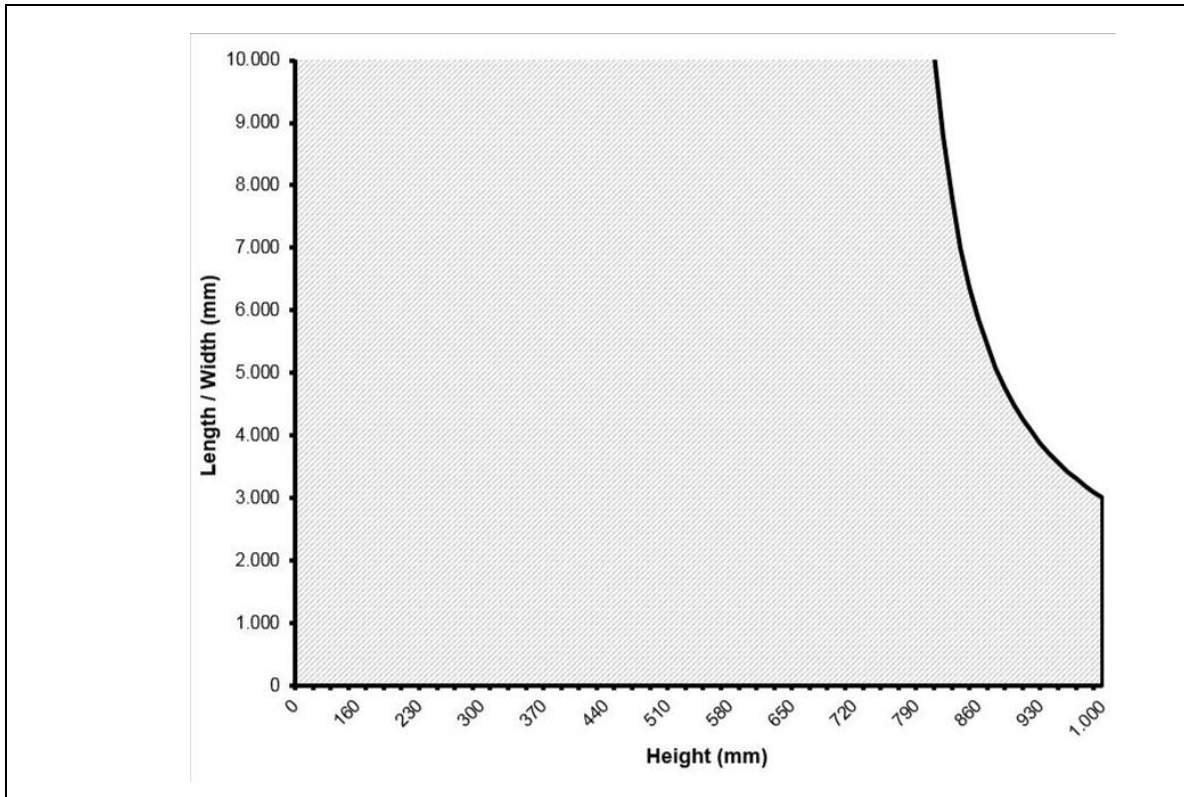

The maximum height of the penetration seal in rigid floors is 1000 mm.

The maximum length (width) of the penetration seal in rigid floors has to be calculated as follows:

$$Length\ (Width) = \frac{Height}{(((c_{tested} / 2) * Height) - 1)}$$

$$c_{tested} = \frac{Perimeter\ length_{tested}}{Seal\ area_{tested}} = 2,667\ m / m^2; \text{ resp. } 0,002667\ mm / mm^2$$

The minimum perimeter length to seal area ratio of the penetration seal in rigid floors is 2,667 m/m<sup>2</sup>, resp. 0,002667 mm/mm<sup>2</sup>.

c<sub>tested</sub> was calculated from the dimensions of the tested penetration seal (3000 mm x 1000 mm).

The area on the left side of the graph gives an overview of all possible combinations of length (width) and height where the minimum perimeter length to seal area ratio is ≥ c<sub>tested</sub>.

For a length (width) of e.g. 3000 mm the allowed height is 1000 mm; for a length (width) of e.g. 4500 mm the allowed height is 900 mm.

For a height smaller than 751 mm no limitation of length (width) is required.

Note: The dimensions of the graph are not true to scale.